



**Tisch Environmental  
TE-Wilbur10  
TE-Wilbur 2.5  
Low Volume Air Particulate Sampler**



## TE-Wilbur Operations Manual Table of Contents

<b>1.0 Introduction</b> .....	<b>8</b>
1.1 TE-Wilbur Overview .....	8
1.2 US EPA FRM Designation .....	9
1.3 Copyrights and Trademarks .....	10
1.4 References .....	10
1.5 Warranty .....	10
1.6 Symbols Used in This Document.....	11
1.7 Safety Warnings .....	11
1.8 Ratings.....	12
1.9 Major Component Diagram .....	13
1.10 Sampler Dimensions for Wilbur PM <sub>2.5</sub> (with TE-PM2.5C) .....	14
1.11 Sampler Dimensions for Wilbur PM <sub>10</sub> (without TE-PM2.5C) .....	15
<b>2.0 Assembly and Installation</b> .....	<b>16</b>
2.1 Packing List.....	16
2.2 Unpacking unit .....	17
2.3 Placing unit on Stand .....	21
2.4 Electrical Connection .....	22
2.5 Other Connections.....	23
2.6 Siting .....	24
2.7 Instrument Setup .....	25
2.8 Choosing Language .....	26
<b>3.0 Quick Start Guide</b> .....	<b>27</b>
<b>4.0 Filter Holder / Filter Handling</b> .....	<b>29</b>
4.1 Filter Holder .....	29
4.2 Operating the Filter Holder.....	31
4.3 Filter Temperature Probe .....	32
4.4 Adjusting the Filter Holder.....	33
4.5 Filter Holder Maintenance.....	33

4.6 Filter and Filter Cassette ..... 34

4.7 Lot, Field and Lab Blanks ..... 36

    Lot Blanks ..... 36

    Field Blanks ..... 37

    Lab Blanks ..... 37

4.8 Filter Pre-Conditioning and Weighing..... 37

    Conditioning of clean unexposed filters ..... 37

    Pre-weighing of unexposed filters ..... 38

4.9 Field Sample Handling..... 39

4.10 Filter Post-Conditioning and Weighing ..... 40

    Conditioning of exposed filters ..... 40

    Using the Filter Cassette Removal Tool (TE-W-400) ..... 40

    Weighing of exposed filters ..... 41

4.11 Calculating Mass Concentrations..... 42

4.12 Data Validation ..... 43

**5.0 PM<sub>10</sub> Inlet / PM<sub>2.5</sub> Cyclone .....44**

    5.1 TE-PM10 Inlet..... 44

    5.2 Cleaning the PM<sub>10</sub> Inlet ..... 45

    5.3 TE-PM2.5C Cyclone ..... 46

    5.4 Cleaning the TE-PM2.5C Cyclone ..... 47

    5.5 Placing of the Cyclone and PM<sub>10</sub> Head ..... 48

**6.0 Sample Setup .....49**

    6.1 Site and Filter ID..... 49

    6.2 USEPA Sample Setup..... 49

    6.3 Custom Sample ..... 54

    6.4 Canceling a Sample ..... 54

    6.5 Sample Alarms ..... 55

    6.6 More Sampling Information..... 57

    6.7 Other Sampling Features ..... 57

**7.0 Calibration .....58**

- 7.1 Ambient Temperature Calibration..... 58
- 7.2 Filter Temperature Calibration ..... 59
- 7.3 Barometric Pressure Calibration..... 61
- 7.4 Volumetric Flow Calculation ..... 62
- 7.5 Flow Calibration ..... 63
- 7.6 Flow Calibration Equations ..... 66
- 7.7 Flow Calibration Audit / Verification ..... 68
- 7.8 Pressure Sensor Zero Trim ..... 69
- 7.9 TE-Wilbur Calibration Worksheet Instructions ..... 70

**8.0 Screen Maintenance .....73**

- 8.1 Changing Date and Time ..... 73
- 8.2 Change Screen Brightness..... 74
- 8.3 Battery Disconnect..... 75
- 8.4 Manual Control ..... 75
- 8.5 System Information ..... 77
- 8.6 Data Download Menu..... 78
- 8.7 Update Firmware ..... 79
- 8.8 Change Sample Setpoint ..... 82
- 8.9 Change MODBUS Address ..... 82
- 8.10 Datalogging Time ..... 83

**9.0 Data Logging / Operational Data .....84**

- 9.1 Operational Data..... 84
- 9.2 Downloading Data to USB..... 85
- 9.3 Datalog..... 86
- 9.4 Erasing the Datalog..... 88

**10.0 History Log .....89**

- 10.1 History Log Introduction ..... 89
- 10.2 Alarms and Events ..... 91
- 10.3 Alarm Flowchart..... 94
- 10.4 History Log Download..... 94
- 10.5 Erasing the History Log ..... 95

**11.0 Leak Checks.....96**

- 11.1 Leak Check Introduction ..... 96
- 11.2 External Leak Check ..... 97
- 11.3 Internal Leak Check..... 99
- 11.4 Leak Check Troubleshooting..... 102

**12.0 Solar / Alternative Energy .....103**

- 12.1 Introduction ..... 103
- 12.2 Solar Wiring Overview ..... 103
- 12.3 Solar Accessories..... 104
- 12.4 Solar Siting Guidelines ..... 104
- 12.5 Solar Controller Operation..... 106
- 12.6 Proper Solar Panel Orientation..... 106
  - Direction to face a solar panel ..... 106
  - Proper Solar Panel Tilt ..... 107

**13.0 Maintenance .....109**

- 13.1 Electrical System ..... 109
  - Turning on the system ..... 109
  - Powering off the system ..... 110
  - Electrical System Layout ..... 111
- 13.2 Fuse Location and Replacement..... 112
- 13.3 Replacing the Batteries ..... 113
- 13.4 Replacing the Screen Internal Battery ..... 114
- 13.5 Sample Pump Maintenance..... 115
- 13.6 Filter Holder Maintenance ..... 119
  - To replace the filter holder o-rings:..... 119

13.7 UPS System Replacement .....	120
13.8 Power Supply Replacement .....	121
13.9 Controller Replacement.....	124
13.10 Flowmeter Replacement.....	128
13.11 Pressure Sensor Replacement .....	129
13.12 Barometric Pressure Sensor Replacement .....	130
13.13 Filter Temperature Probe Replacement .....	132
13.14 Ambient Temperature Replacement .....	132
13.15 Solenoid Replacement .....	133
13.16 Pump Controller Replacement .....	135
13.17 Touch Screen Replacement .....	137
13.18 Power Button Replacement.....	139
13.19 Power Fail Relay Replacement.....	141
13.20 Louver Filter Media Replacement.....	144
<b>14.0 Troubleshooting .....</b>	<b>145</b>
14.1 Service Locations .....	145
14.2 Electrical System .....	145
14.3 Touchscreen Troubleshooting .....	147
14.4 Flowmeter.....	149
14.5 Barometric Pressure .....	150
14.6 Temperature Sensors.....	151
14.7 Pump system.....	152
14.8 Pressure Sensor .....	153
14.9 Solenoid .....	154
14.10 Exhaust Fan.....	154
14.11 Lighting Strip .....	155
14.12 Solar / Alternative Energy.....	155
14.13 Communications .....	155

**15.0 Communications .....156**

- 15.1 Introduction ..... 156
- 15.2 Ethernet Connection..... 156
- 15.3 Webserver Functions ..... 158
- 15.4 Remote Data Upload..... 160
- 15.5 MODBUS Configuration ..... 162
- 15.6 MODBUS Data Map ..... 164

**Appendix A: Parts List .....166**

- A.1 Parts List ..... 166
- A.2 Filter Holder Parts List ..... 169
- A.3 Optional Accessories ..... 171
- A.4 Solar Option Parts List ..... 171
- A.5 O-Ring Replacement Part Numbers..... 171

**Appendix B: Drawings.....172**

- B.1 Electrical Terminal TB1 connections..... 172
- B.2 TE-Wilbur Drawings ..... 173
- B.3 Enclosure Stand Drawing..... 176
- B.4 TE-PM2.5C Drawing..... 177
- B.5 TE-PM10 Drawings..... 178

**Appendix C: Revision History .....180**

**Appendix D: Software Revision History.....182**

# 1.0 Introduction

This instrument (TE-WILBUR) is named to honor Wilbur P. Tisch, an innovator and pioneer in the design and construction of particulate monitoring instruments since the 1950s. Wilbur and his father contracted with the US Department of Public Health (before the US EPA was commissioned) to develop a high volume air sampler which would become the first active particulate monitoring instrument used to monitor particulate matter in ambient air. As a result of Wilbur's 60+ years in this industry, more than one million instruments have been put to work collecting air samples that have been used to learn the effects and health issues of particulate concentrations in our air. Wilbur serves as the Ambassador of Tisch Environmental while working with his three sons Bob, Jim and John. Wilbur's rich work ethic, diligence, productiveness and conscientious attitude have laid the foundation for the success of Tisch Environmental. With four generations of experience, leadership and know-how, the Tisch family would like to welcome you to the company and thank you for choosing Tisch Environmental.

## 1.1 TE-Wilbur Overview

TE-Wilbur is a filter-based, ambient air particulate sampler. The USEPA has designated it a federal reference method for the collection of  $PM_{2.5}$  and  $PM_{10}$  particulates using model number TE-Wilbur2.5 for  $PM_{2.5}$  and TE-Wilbur10 for  $PM_{10}$ . This product is capable of collecting several different size fractions of particulate matter. When configured for collection of  $PM_{10}$ , only the  $PM_{10}$  size selective inlet (TE-PM10-D) is installed. When configured to collect  $PM_{2.5}$ , the TE-PM2.5C cyclone or WINS impactor is installed downstream of the  $PM_{10}$  size selective inlet. A TSP (Total Suspended Particulate) option is also available.

The unit has many features that make operation very simple and straightforward. The unit utilizes a full-color active touch screen and menus that makes operation quick and easy to understand. Operation of the unit is simple, with screens guiding the operator each step of the way. Sample run summary data is downloaded with a USB thumb drive and presented in a .CSV format. The system monitors and records all system sensors such as flow, temperatures and barometric pressure, and also records the system pressure, filter temperature variation, and flow total which provides the operator or laboratory technician additional information on the sample if warnings or alarms occurred during the sample run. The system runs solely from 24VDC power. An Uninterruptible Power Supply (UPS) is incorporated into the system that allows the system to keep operating for several hours



during a power loss. Although this system is not intended for running a full 24 hour sample without mains power, the system includes an external power connection that can be used to connect larger external batteries, solar, wind or any other 24VDC alternative energy sources. Help menus are included on the screen to assist the operator with calibration, leak checking and other features of the system. The system provides remote Ethernet control and monitoring from any standard browser and a Modbus interface for remote telemetry connections.

## 1.2 US EPA FRM Designation

The US EPA has designated the Tisch Environmental TE-Wilbur10 and TE-Wilbur2.5 as a Federal Reference Method (FRM) and a Federal Equivalency Method (FEM) per the table below for the measurement of particulate matter in ambient air based on the requirements of 40 CFR Part 53. This unit is a gravimetric method and meets all requirements of 40 CFR Part 50 Appendix L and has been tested and meets the requirements of 40 CFR Part 53.

Method	Configuration	Designation Type	Designation Number
PM <sub>10</sub>	TE-PM10-D PM <sub>10</sub> head	FRM	RFPS-0714-216
PM <sub>2.5</sub>	TE-PM10-D PM <sub>10</sub> head with VSCC Cyclone or WINS Impactor	FRM	RFPS-1014-219
PM <sub>2.5</sub>	TE-PM10-D PM <sub>10</sub> head TE-PM2.5C Cyclone	FEM Class II	EQPS-0415-223
PM <sub>10-2.5</sub> *Requires collocation of (2) samplers	Sampler 1: (PM <sub>2.5</sub> ) TE-PM10-D PM <sub>10</sub> head with VSCC Cyclone or WINS Impactor  Sampler 2: (PM <sub>10</sub> ) TE-PM10-D PM <sub>10</sub> head	FRM	RFPS-1014-220
PM <sub>10-2.5</sub> *Requires collocation of (2) samplers	Sampler 1: (PM <sub>2.5</sub> ) TE-PM10-D PM <sub>10</sub> head with TE-PM2.5C  Sampler 2: (PM <sub>10</sub> ) TE-PM10-D PM <sub>10</sub> head	FEM Class II	EQPS-0415-224

### 1.3 Copyrights and Trademarks

The 'Wilbur' trade name and Tisch logos are copyrights of Tisch Environmental, Inc. The software used in this instrument is proprietary intellectual property of Tisch Environmental and is not to be reproduced or replicated in any way.

### 1.4 References

This manual references the *US EPA Quality Assurance Guidance Document 2.12, Monitoring PM<sub>2.5</sub> in Ambient Air Using Designated Reference or Class I Equivalent Methods* which can be obtained from the Human Exposure and Atmospheric Sciences Division at the National Exposure Laboratory, Research Triangle Park, NC 27711. Updates to this document will take precedence over materials contained in this operations manual.

### 1.5 Warranty

Instruments manufactured by Tisch Environmental, Inc. are guaranteed by warranty to be free of defects in materials and workmanship for one year after shipment from Tisch Environmental factories. The liability of Tisch Environmental, Inc. is limited to servicing or replacing any defective part of any instrument returned to the factory by the original purchaser. All service traceable to defects in original material or workmanship is considered warranty service and is performed free of charge. The expense of warranty shipping charges to and from our factory will be borne by Tisch Environmental. Service performed to rectify an instrument malfunction caused by abuse, acts of god or neglect, and service performed after the one-year warranty period will be charged to the customer at the current prices for labor, parts, and transportation. The right is reserved to make changes in construction, design specifications, and prices without prior notice.

## 1.6 Symbols Used in This Document

The following symbols are used in this document



Shock hazard – this symbol is used to make the operator aware that there is a potential for an electrical shock hazard



General Attention – this symbol is used to make the operator aware of an important directive

## 1.7 Safety Warnings



Service and repair of this instrument should only be attempted by a trained technician whom is familiar with electrical safety.



Do not remove the inner enclosure covers without disconnecting mains power and powering down the unit completely.



Use grounded electrical connections at all times to prevent inadvertent electrical shock hazards.



Only use outdoor rated cords to supply mains power to the instrument. The power cord supplied with the instrument has an outdoor rated insulation.



Care should be taken when operating the filter holder mechanism that fingers do not get pinched in the mechanism.



When installing the unit outdoors, ensure the unit is securely fastened to a level, hard surface and that measures are taken to prevent the unit from tipping over.

## 1.8 Ratings

<b>Electrical</b>	<p>120 VAC / 60 Hz / 0.5 Amps                  230 VAC / 50 Hz / 0.25 Amps                  Minimum Mains voltage 100 VAC                  Maximum Mains voltage 240 VAC</p> <p>Mains power is interrupted by a 1 amp circuit breaker.</p> <p>The system operates from a 24 VDC / 60 watt power supply that is fused at 2.5 amps using a quick-blow fuse.</p>
<b>Temperature</b>	-25°C to 50°C
<b>Weight</b>	<p>47 lbs / 21.8 kg without stand                  40 lbs without stand and battery pack                  83 lbs total shipping weight complete                  Shipping dimensions: 19x31x42" (48.3x78.7x106.7cm)</p>
<b>Dimensions</b>	20"W x 20"H x 10"D / 508 mm x 508 mm x 254 mm
<b>Flow System</b>	Range 0 – 25 Liters per minute with an accuracy of $\pm 3\%$ of full scale (0.75 Lpm) with a repeatability of $\pm 1\%$ of full scale (0.25 Lpm) and resolution of 0.01 Lpm.
<b>Ambient Temperature</b>	The ambient temperature sensor is a PT100 RTD with an accuracy of $\pm 0.15^\circ\text{C}$ and a resolution of $0.01^\circ\text{C}$ .
<b>Filter Temperature</b>	The filter temperature sensor is a PT100 RTD with an accuracy of $\pm 0.15^\circ\text{C}$ and a resolution of $0.01^\circ\text{C}$ .
<b>Barometric Pressure Sensor</b>	The barometric pressure sensor is ranged 450 mmHg to 1238 mmHg and has an accuracy of $\pm 10.00$ mmHg and a resolution of 0.75 mmHg.

## 1.9 Major Component Diagram

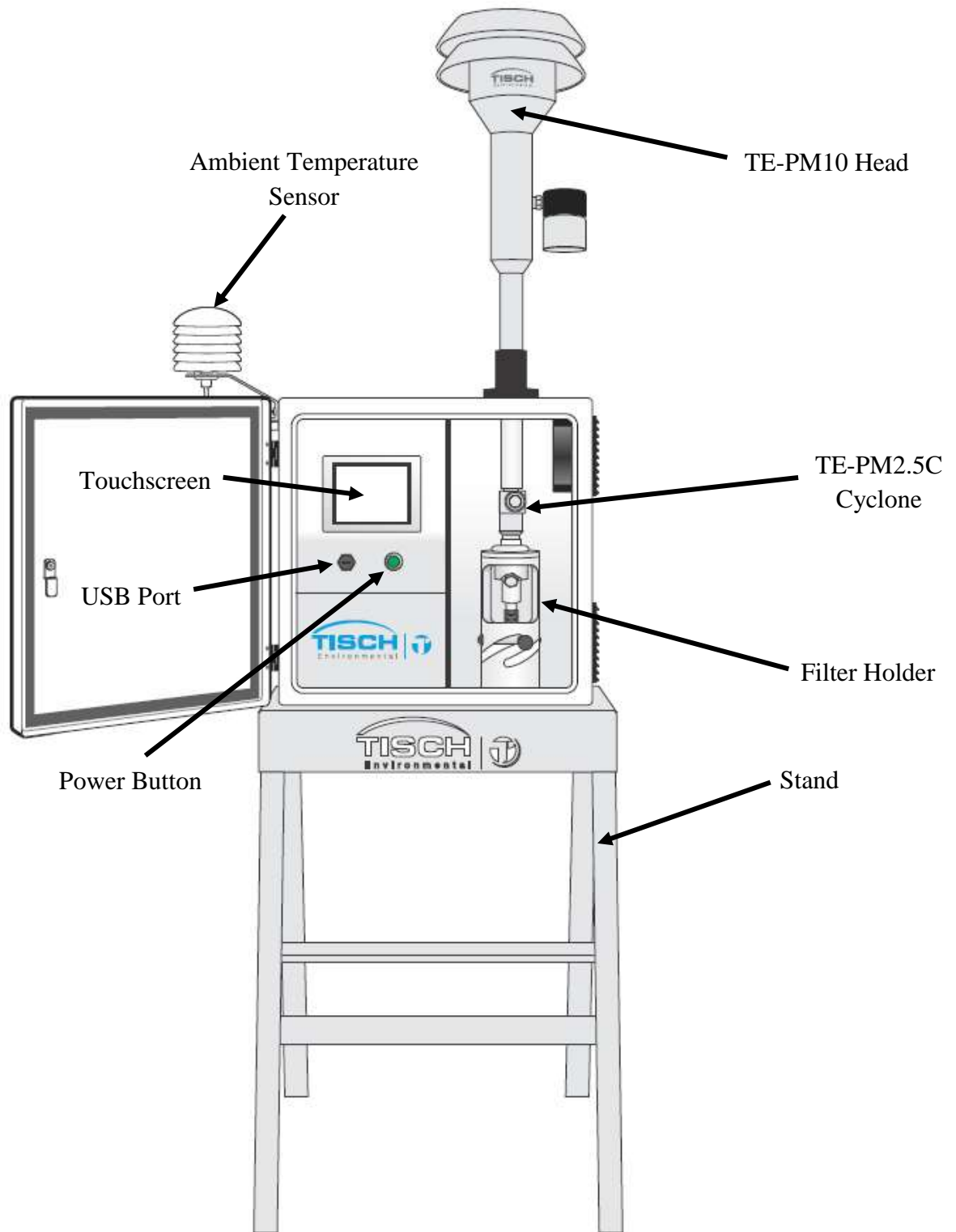

### 1.10 Sampler Dimensions for Wilbur PM<sub>2.5</sub> (with TE-PM2.5C)

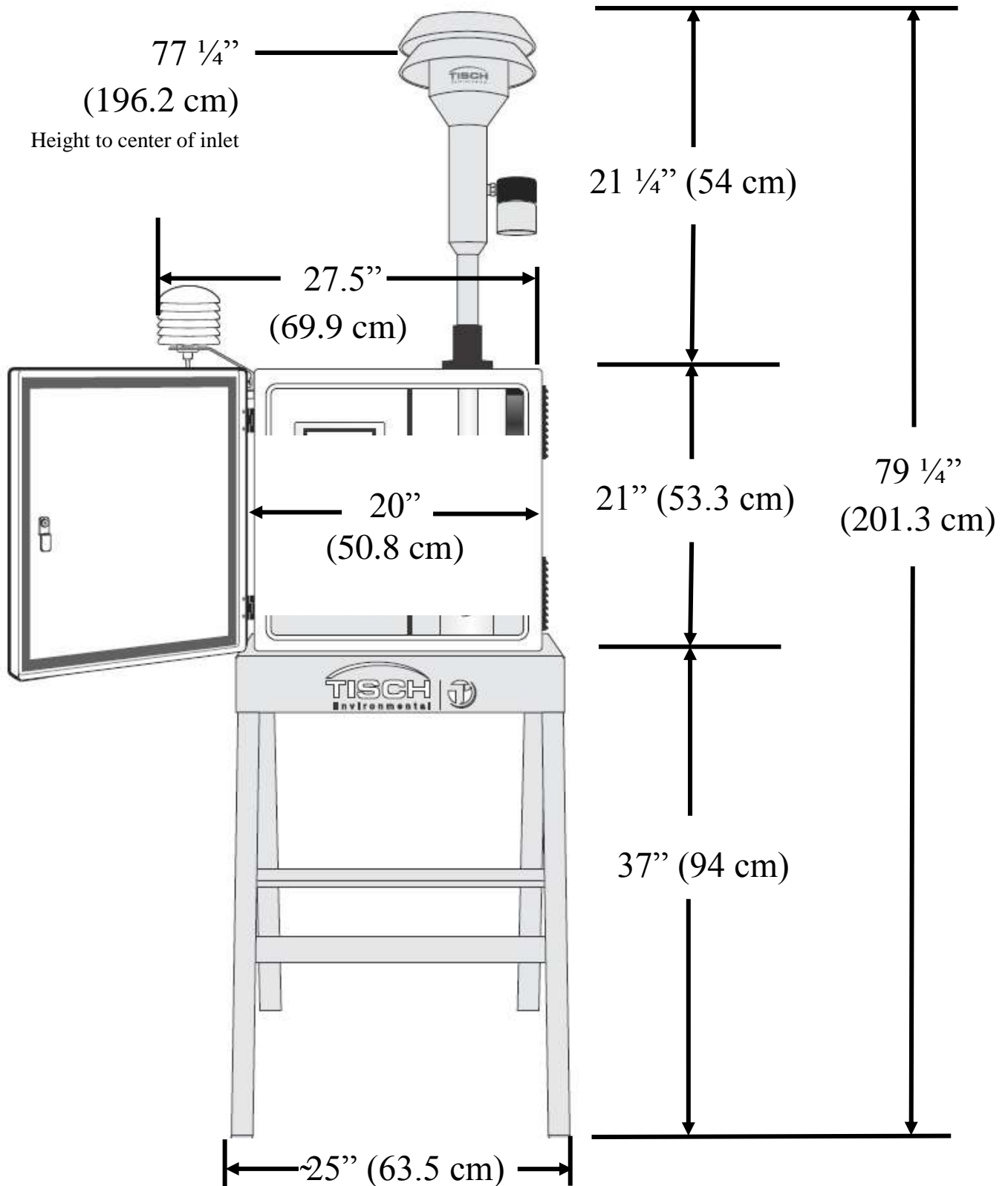

### 1.11 Sampler Dimensions for Wilbur PM<sub>10</sub> (without TE-PM2.5C)

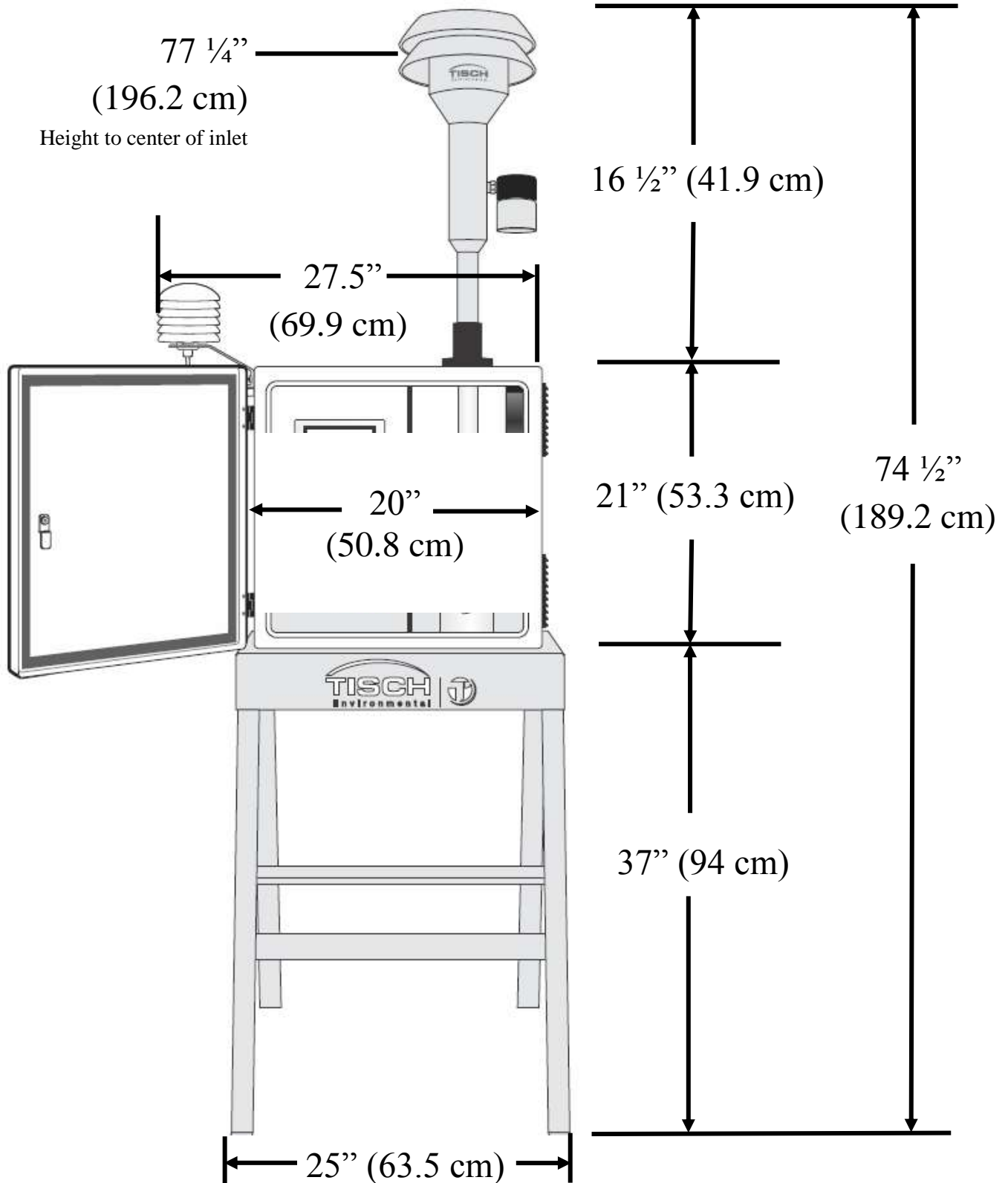

## 2.0 Assembly and Installation

This section describes the unpacking, assembly and installation of TE-Wilbur.

### 2.1 Packing List

The TE-Wilbur PM sampler is packed in one complete box with the following packing components.

Quantity	Part Number	Description
1	TE-Wilbur2.5/10	TE-Wilbur unit configured either for PM <sub>2.5</sub> or PM <sub>10</sub> collection
1	TE-PM-10-D	Tisch Environmental PM <sub>10</sub> head with downtube
1	TE-PM2.5C	TE-PM2.5C cyclone fractionator
1	TE-W-STAND	Stand with (4) 1/4-20 x 3/4" SS bolts, (2) Mounting brackets and (8) 1/4-20 x 3/4" SS bolts for mounting enclosure to stand
1	TE-W-151	Ambient temperature probe with radiation shield
1	TE-FH47	Filter cassette with screen, tin and anti-static bag
1	TE-W-004	Internal Leak Check Disk
1	TE-W-005	Product Manual
1	TE-W-107	USB stick
2	TE-W-062	1/4-20 x 5/8" SS bolts to mount ambient temperature probe and shield
1		Build summary / Testing checklist



## 2.2 Unpacking unit

The TE-Wilbur is packed in one complete box. To unpack the unit, follow these steps:

1. Place the box in the upright position and open one of the sides.

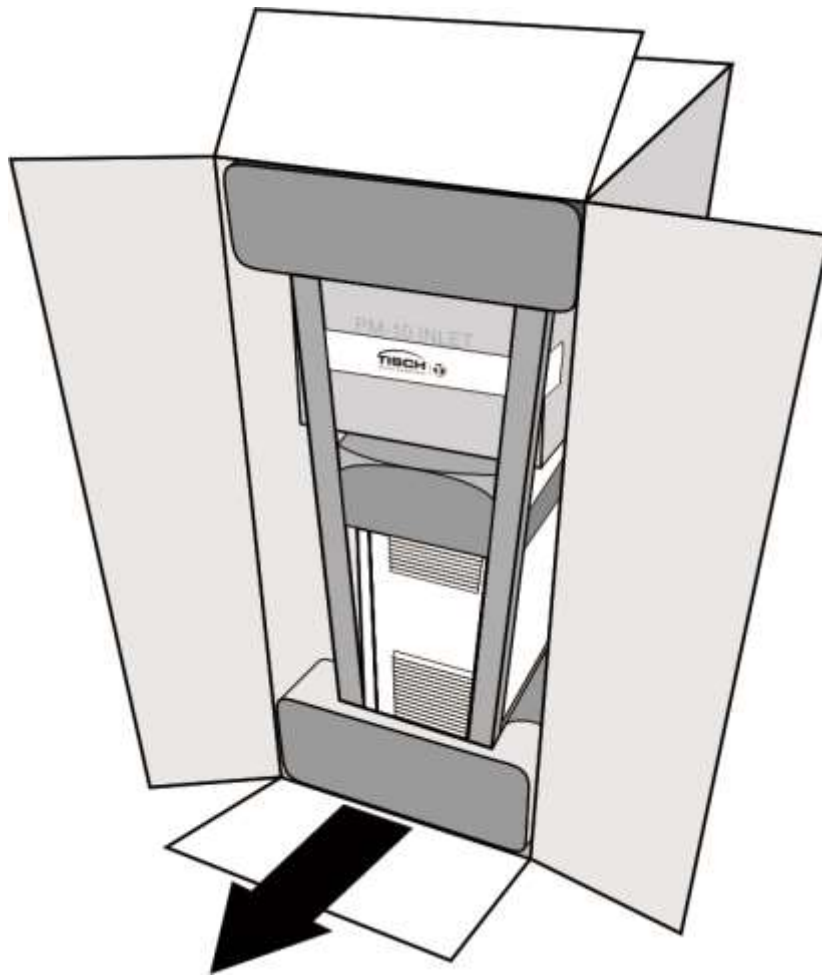

2. Remove the entire unit from the box by pulling from the bottom portion of the stand, sliding it from the box.

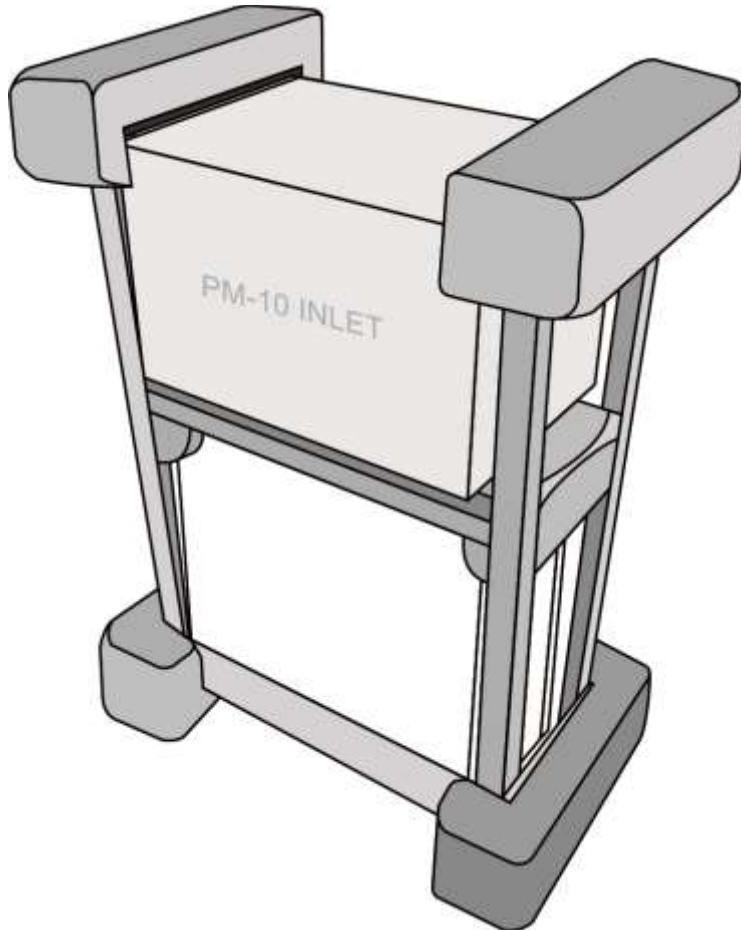

3. Remove the two top foam inserts and the top box, which will contain the PM<sub>10</sub> head and/or cyclone and all of the miscellaneous parts and instruction manual.

4. Spread the stand legs apart and remove the two foam inserts on top of the enclosure.

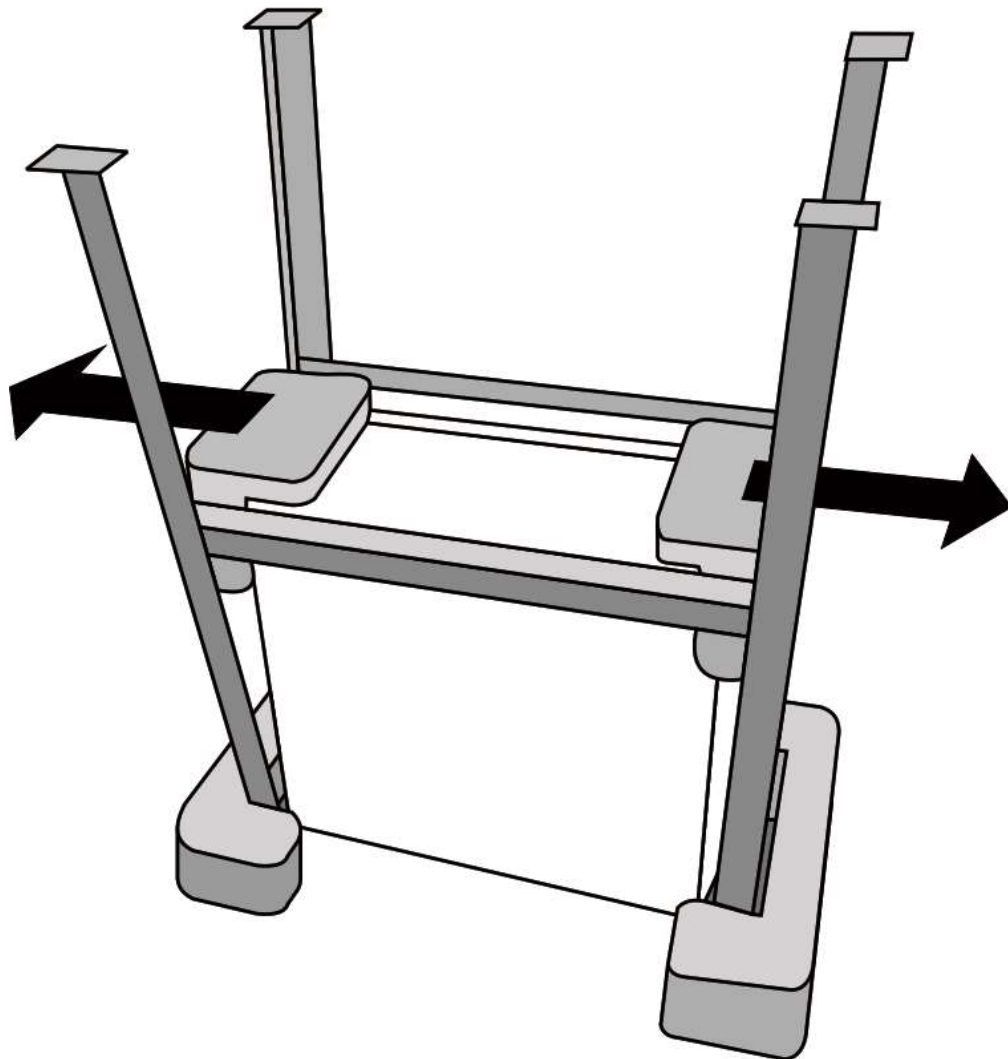

5. Remove the TE-Wilbur sampler from inside of the stand and remove the stand from the bottom two foam inserts

6. Place the stand in the upright position.
7. Using the (4) supplied 1/4-20 x 3/4" stainless steel bolts, secure the stand legs by screwing in one bolt on each side of the stand top/leg as shown.

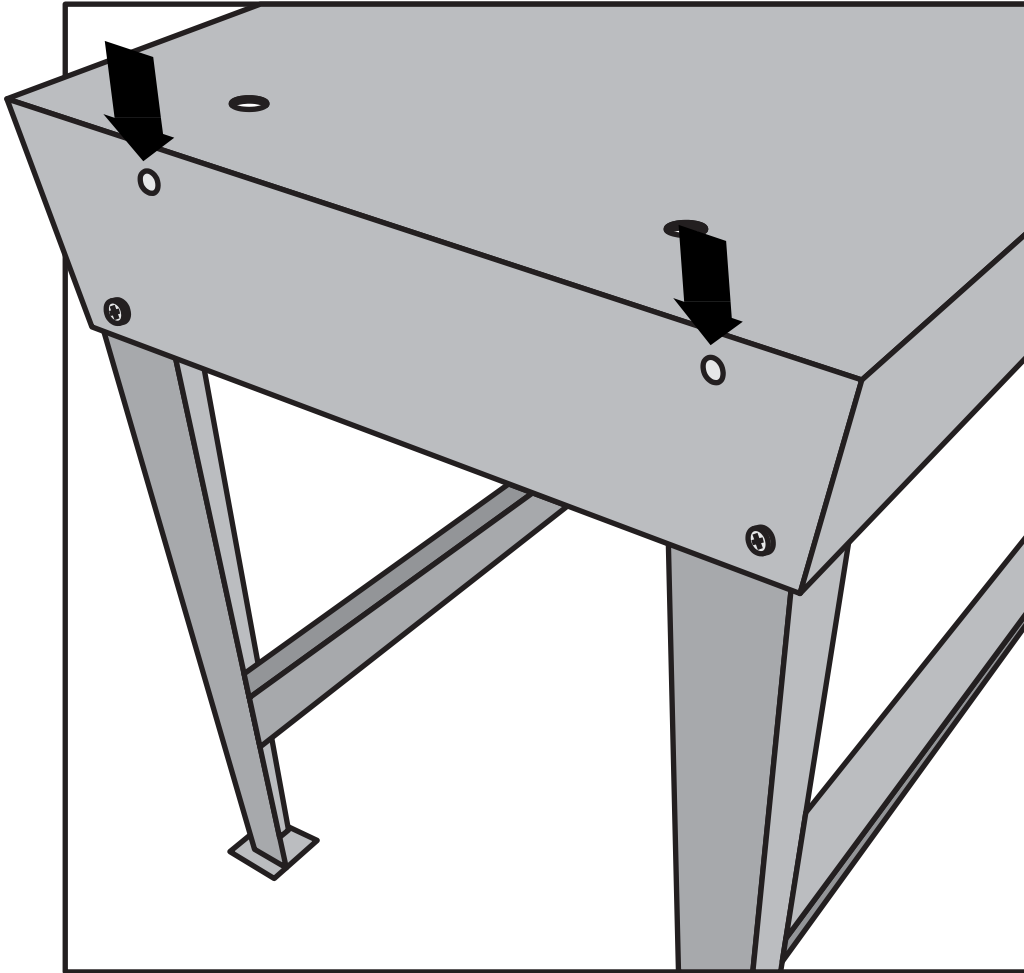

## 2.3 Placing unit on Stand

The TE-Wilbur sampler is supplied with an enclosure stand that allows the inlet to be placed 2m ± 0.2m above ground. To place the sampler on the stand, follow these steps:

1. Unpack the stand and enclosure.
2. Place the stand on a level surface.
3. Secure the stand. The stand has holes in the feet that can be used to secure the unit to a level surface. The use of sandbags can also secure the unit to a level surface to prevent the unit from being knocked over.



**NOTE:** The stand needs to be secured to prevent tipping over and causing injury or damage to the unit.

4. Place sampler on top of stand, aligning the two holes on either bottom side with the bracket holes located on the side of the stand.

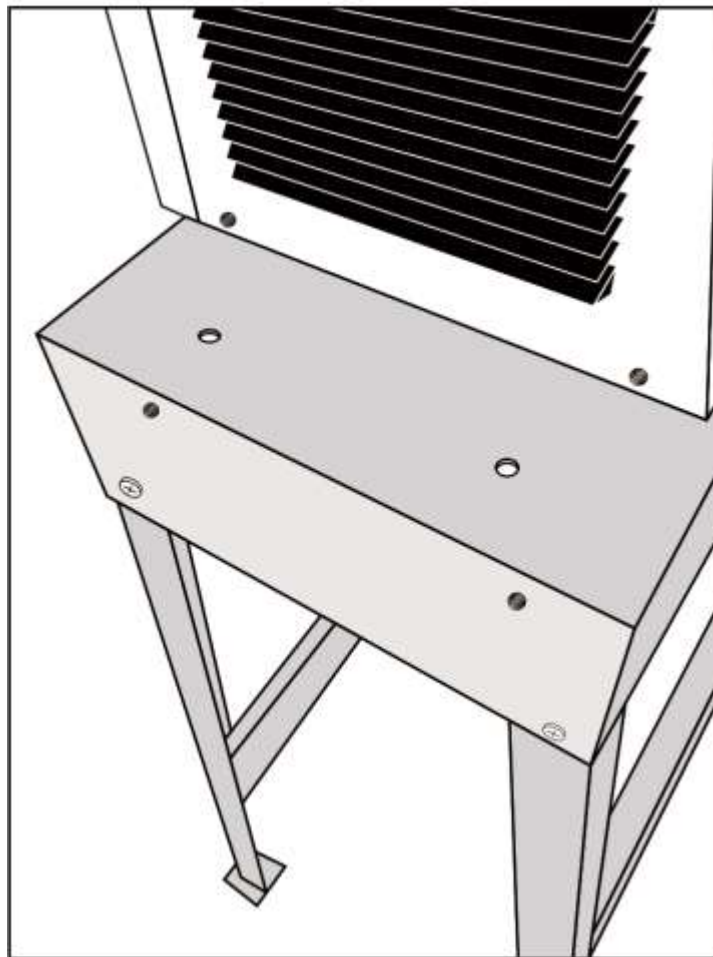

5. Place one of the mounting brackets onto the stand, aligning the holes in the stand and the enclosure with the holes in the mounting bracket. Secure the stand and the enclosure to the mounting bracket using the supplied 1/4-20 x 3/4" stainless steel bolts. Repeat for the other side. A total of (8) bolts are used to secure the enclosure to the stand.

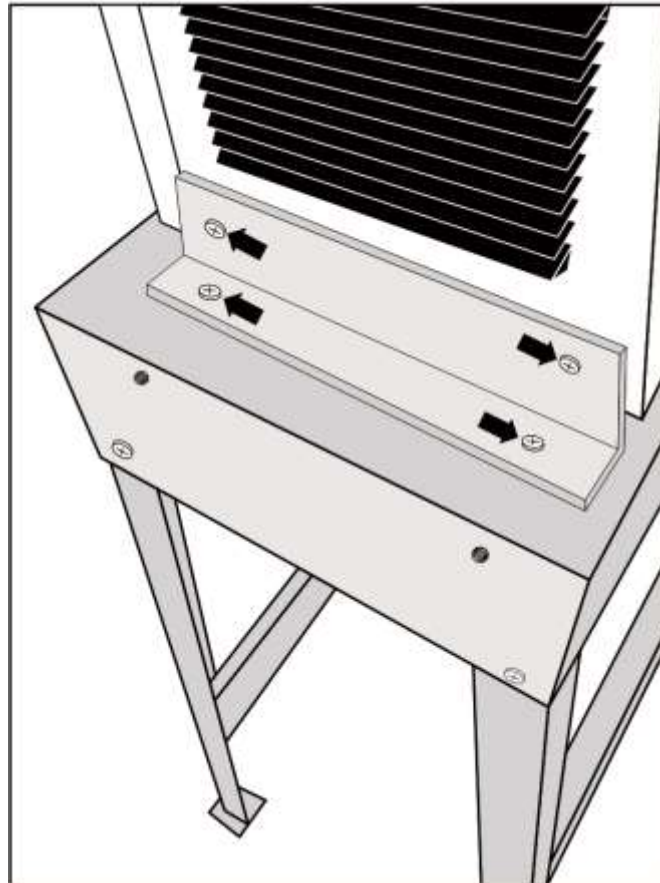

## 2.4 Electrical Connection

The TE-Wilbur sampler is configured with a universal IEC320 socket that is located in the weatherproof side box. A standard USA-style cord is supplied with each unit. Contact Tisch Environmental for different cord-end options.

A 1 amp AC circuit breaker that is resettable is also located in the side box below the power socket.



**NOTE:** Always use grounded connections when connecting AC mains to the unit. Shock hazards could result if proper grounding is not followed or if outdoor-rated cords are not used. If using extension cords inspect for wear and damage and follow all local and national electrical codes for installation.

## 2.5 Other Connections

There are 3 other connections external to the sampler that are located in the weatherproof side box.

**MODBUS** RJ11 connection – 2-wire serial Modbus cable part number: TE-W-501. See section 15.0 - Communications for MODBUS information.

**Solar / 24VDC** Connection to supply unit with remote 24VDC - batteries, solar, wind or other alternative energy sources. External 24VDC connection cable part number TE-W-502. See section 12.0 for more information.

**Ethernet** For remote monitoring and control – RJ45 Ethernet cable part number: TE-W-503. See section 15.0 for Ethernet information.

### External Connections



## 2.6 Siting

Siting is important for proper collection of PM<sub>2.5</sub> or PM<sub>10</sub> particulate matter. Refer to 40CFR Part 58, Appendix D and the guidance document for network design and optimum site exposure for PM<sub>2.5</sub> and PM<sub>10</sub> published by the US EPA Office of Air Quality Planning and Standards (OAQPS).

The following installation guidelines should be observed:

- The sampler must have an unobstructed air flow for a minimum of 2 meters in all directions. Provide sufficient area for a collocated FRM sampler and for installation of a portable FRM performance evaluation (PE) sampler.
- The sampler's inlet should be placed at a height of 2-15m above ground level.
- If the sampler is collocated with any other samplers, the spacing between sampler inlets must be greater or equal to 1m if the other samplers are low-volume (16.67 Lpm and below). If high-volume samplers are collocated next to the sampler, the spacing between sampler inlets must be greater or equal to 2m. The spacing between any air inlets should be no more than 4m.
- Location safety – ensure to locate the unit in a safe location that can be accessed easily and that routine maintenance can be performed by the operator easily and safely. The unit weighs over 40lbs so care must be taken if ladders are needed to access the sampling site.
- Location security – ensure to locate the units in areas that are well secured such as on rooftops with locked access and ground level sites with fencing. If the ground level site has fencing, ensure it is chain link and does not impede air flow. The sampler's inlet should extend above the fence.



## 2.7 Instrument Setup

Prior to field installation, it is recommended to get familiar with the operation and use of the sampler. Once operators are familiar with the operation of the unit the following should be followed for proper field operation

- Follow the siting guidelines in 2.6.
- Place the stand on a level surface and secure if necessary with screws or sand-bags to prevent strong winds from knocking over unit.
- Place the sampler onto the stand and secure with the (8) provided bolts and brackets
- Place the downtube through the hole on top of the unit and push down into unit. If sampling for PM<sub>10</sub>, push the downtube onto the top of the filter holder. If sampling for PM<sub>2.5</sub>, place the TE-PM2.5C cyclone on top of the filter holder first, then push the downtube onto the cyclone.
- Place the PM<sub>10</sub> head on top of the downtube.
- Attach the ambient temperature probe and radiation shield onto the left side of the enclosure with (2) 1/4-20 x 5/8" bolts and screw in the cable connection to the socket.
- Plug the sampler into a reliable AC electrical source that is grounded.
- Turn on the unit by pressing the green power button on the inside front cover of the unit.
- Allow the unit to equilibrate to ambient conditions. This could take up to an hour if ambient temperatures are very warm or cold.
- Set the time and date.
- Perform an external leak check.
- Perform a calibration check of the temperatures, barometric pressure and flow system– unit comes from the factory pre-calibrated.
- Enter the site ID.
- Turn power off by pressing the green power button and make sure the unit remains powered on the batteries.
- Turn power back on.
- Setup a sample and install a clean filter, enter the filter ID.
- The unit is ready for field operation.

## 2.8 Choosing Language

When the TE-Wilbur instrument is powered up, the following splash screen will appear:



This screen will allow the instrument's language to be changed. Available languages are English (US), Spanish and Chinese.

In order to change the language the instrument must be powered down completely.

## 3.0 Quick Start Guide

The TE-Wilbur system comes from the factory with the following functions performed:

- Leak Check Passed
- Flow System Calibrated
- Ambient Temperature Calibrated
- Filter Temperature Calibrated
- Barometric Pressure Calibrated
- Pressure sensor zeroed
- 48-hour burn-in test running at 16.67 Lpm
- Time and Date set for Eastern Time (UTC -5.00, Eastern Time)

<b>Perform the following to place unit in service:</b>	<b>Manual Section</b>
Unpack Unit from Shipping Box.	2.2
Determine sampling location	2.6
Place stand on level surface and secure stand with sand-bags or screw onto a fixed surface. Place the sampler onto the stand and secure with (8) ¾” ¼-20 bolts (included) and mounting brackets.	2.3
Secure the ambient temperature radiation shield / probe onto left side of unit with (2) ¾” ¼-20 bolts (included) and screw the probe connection into the socket.	2.7
Place the Cyclone on top of the filter holder, place the downtube through the downtube adapter and push onto the top of the cyclone (if configuring for PM <sub>10</sub> do not place the cyclone onto the filter holder) Leave the PM <sub>10</sub> head off for now in order to perform a leak check.	5.5
Plug the unit into an AC power source and press the green button to power on unit.	2.7
Unit should power on – if problems see Troubleshooting – Section 13.0.	
At the splash screen, choose your language.	
If you are not in EST time zone, change the time and date if necessary by going to: MAINTENANCE➔SET TIME AND DATE.	8.1

- Perform an external leak check by placing the L30 leak check adapter on top of the down-tube and closing the valve. Then go to:  
**MAIN MENU → PERFORM LEAK CHECKS** 11.0
- Perform a flow calibration check of the flow system by going to:  
**CALIBRATION → FLOW CALIBRATION CHECK** 7.7  
 If the flow is within 4% no action is needed. If flow is not accurate, then a flow calibration must be performed. See section 6.5.
- Check the barometric pressure, filter temperature and ambient temperature sensors, the values can be found by going to:  
**MAIN MENU → OPERATIONAL DATA** 7.0  
 If the sensors are not reading correctly, a calibration must be performed see section 6.0 – Calibration.
- Enter the Site ID and Filter ID by going to:  
**SAMPLE SETUP → ENTER SITE AND FILTER ID** 6.1
- Choose the sample you would like to perform and the starting day:  
**SAMPLE SETUP → SET TO SAMPLE 1 in 6 DAYS** (for example) 6.2
- Place the PM<sub>10</sub> head onto the top of the downtube. 5.5
- Place a clean filter into the filter holder and close the filter holder. 4.0
- Close the enclosure of unit.
- After sampling is complete, insert a USB thumb drive into the USB port and press download run summary data. After data downloads press ‘EJECT USB’ to eject the USB drive and then remove the USB drive. 9.0
- Remove dirty filter and record all data as required by your agency.
- Place a new filter in the filter holder and close the filter holder.
- Update the filter ID and ensure the unit is still setup for the sample type you are running. The sample control screen will show the next date of the sample.. 9.0

## 4.0 Filter Holder / Filter Handling

This section describes the TE-Wilbur Filter Holder and Filter Handling.

### 4.1 Filter Holder

The TE-Wilbur filter holder is used to hold the filter and filter cassette in place while sampling. The filter holder exploded view diagram is below:

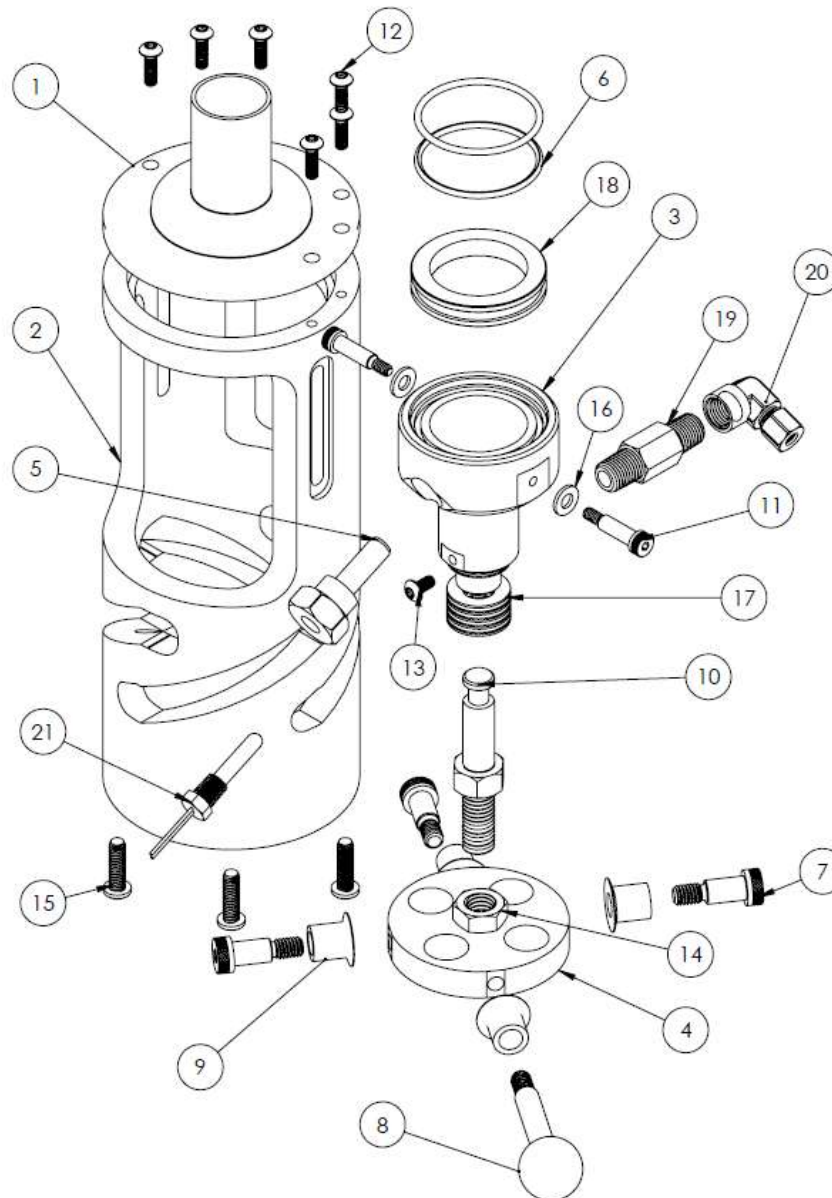

<b>Number</b>	<b>Part Number</b>	<b>Description</b>
1	TE-W-FH1	Top mate
2	TE-W-FH2	Helix Lever Base
3	TE-W-FH3	Bottom mate
4	TE-W-FH4	Cam lever plate
5	TE-W-FH5	Thermowell
6	TE-W-FH6	Bottom and top mate o-rings (Qty 2)
7	TE-W-FH7	5/16-18 shoulder bolt (Qty 3)
8	TE-W-FH8	Lever handle with ball (stainless steel)
9	TE-W-FH9	Cam bushing (Qty 4)
10	TE-W-FH10	Drive rod
11	TE-W-FH11	10-24 shoulder bolt (Qty 2)
12	TE-W-FH12	10-32 socket cap screw (Qty 6)
13	TE-W-FH13	Set screw
14	TE-W-FH14	Drive rod nut
15	TE-W-FH15	1/4-20 mounting bolts (Qty 4)
16	TE-W-FH16	PTFE washer (Qty 2)
17	TE-W-FH17	Belleville washers (Qty 10)
18	L27/L28/L29	Filter Cassette
19	TE-W-FH19	Filter holder hex nipple
20	TE-W-FH20	Compression fitting elbow
21	TE-W-152	PT100 RTD Filter Holder Temperature Probe

## 4.2 Operating the Filter Holder

Opening and closing the filter holder is accomplished by sliding the ball lever handle to the far left to open and to the far right to close. When in the final closed position the ball lever handle will ‘click’ in place.

Filter holder in the open position

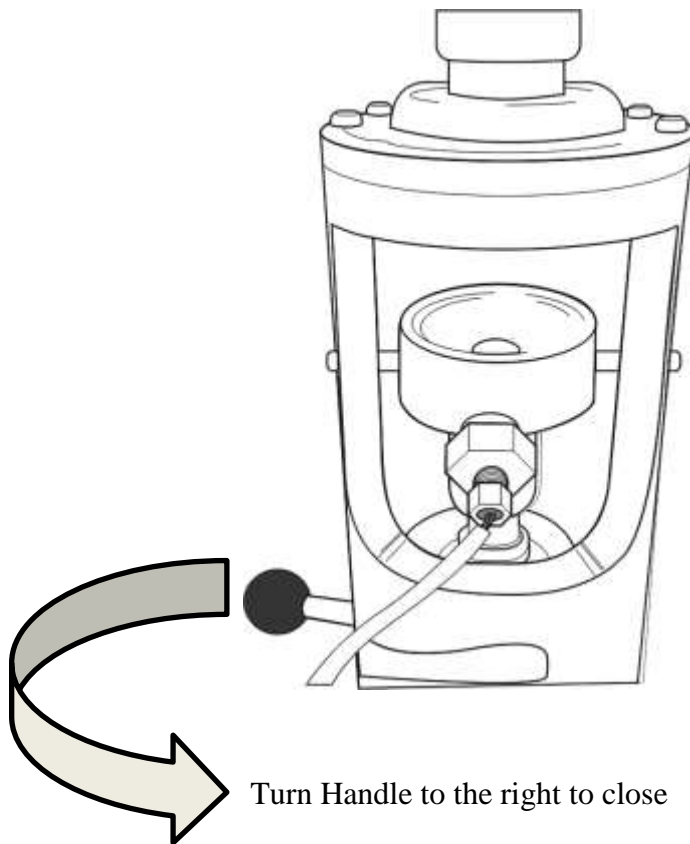

Turn Handle to the right to close

Filter holder in the closed position

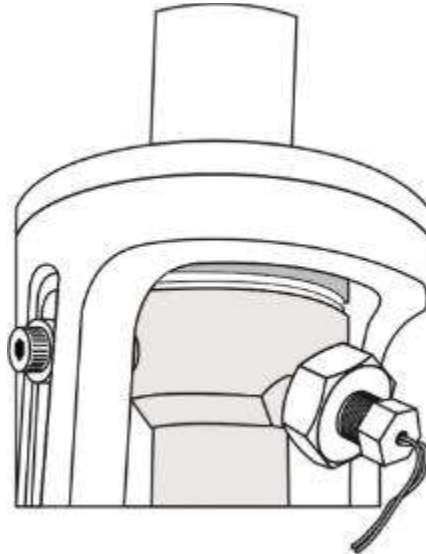

### 4.3 Filter Temperature Probe

The filter holder temperature probe is located in the bottom mate section of the filter holder and measures the temperature of the filter. It is housed inside of a thermowell. This thermowell is secured into the bottom mate and should never have to be removed. The filter temperature probe can be easily threaded into the thermowell by hand.

Illustration showing filter temperature probe

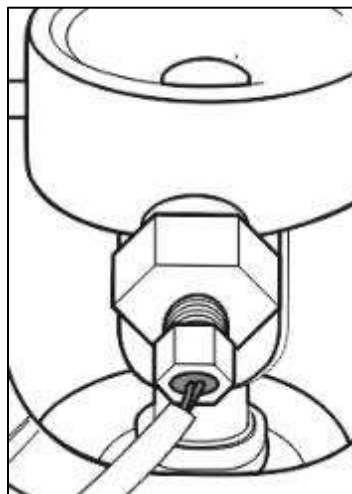



## 4.4 Adjusting the Filter Holder

The filter holder is factory adjusted and will likely never need adjustment. If the assembly should become loose and require adjustment, perform the following steps:

1. Loosen the drive rod nut (see item 14 in section 4.1) with a  $\frac{3}{4}$ " wrench and turn counterclockwise a few turns.
2. The drive rod (see item 10 in section 4.1) should now be able to be turned freely.
3. To tighten the filter holder mechanism turn the drive rod in a counterclockwise rotation a few turns with the filter holder wrench, turning it out of the cam lever plate (see item 4 in section 4.1).
4. To loosen the filter holder mechanism turn the drive rod in a clockwise location, turning it a few turns into the cam lever plate.
5. Test the tightness or looseness of the drive rod by opening and closing the filter holder.
6. Keep turning the drive rod until the desired tightness or looseness is achieved, and then tighten the drive rod nut by turning clockwise with the filter holder wrench securing it and the drive rod onto the cam lever plate.

## 4.5 Filter Holder Maintenance

The filter holder is maintenance free with the exception of tightening or loosening the mechanism if the system should become loose or is having an issue passing a leak check.

There are o-rings on the top and bottom mate pieces that seal the filter cassette. If there appears to be a leak in the system, inspect these for wear or damage. Replace if needed. See section 13.0 Maintenance for instructions on replacing the o-rings on the filter holder.

The filter holder should be cleaned on a monthly basis to keep stray particulate matter from affecting sampling results. The inside of the bottom and top mate and the top tube can be cleaned with distilled water or a general purpose cleaner and a soft cloth.

## 4.6 Filter and Filter Cassette

The filter specifications for PM<sub>2.5</sub> and PM<sub>10</sub> sampling are detailed in *EPA QA Guidance Document 2.12 – Monitoring PM<sub>2.5</sub> in Ambient Air Using Designated Reference for Class I Equivalent Methods* and are as follows:

- Material – PTFE Teflon with integral support ring.
- Size- circular 46.2mm diameter +/- 0.25mm (with support ring).
- Support ring – Polymethylpentene (PMP) or equivalent inert material, 0.38 ± 0.04mm thickness, outer diameter 46.2 ± 0.25mm, and width of 3.68mm.
- Pore size – 2µm as measured by ASTM F 316-94.
- Thickness – 30-50µm.
- Maximum pressure drop of a clean filter is 30cm of water column at 16.67 L/min clean air flow.
- Maximum moisture pickup – no more than 10µg weight increase after 24 hour exposure to air at 40% RH, relative to the weight after a 24 hour exposure to air at 35% RH.
- Collection efficiency – greater than 99.7% as measured by the dioctyl phthalate (DOP) test (ASTM 1995c) with 0.3µm particles at the sampler’s operating face velocity.
- Filter weight stability (including test for loose, surface-particle contamination and test for temperature stability) - filter weight loss ≤ 20µg in either test, measured as specified in 40CFR Part 50, App. L, section 6.9.
- Alkalinity – less than 25 micro-equivalents/g of filter, as measured in a procedure based on Appendix A of *EPA QA Guidance Document 2.12 – Monitoring PM<sub>2.5</sub> in Ambient Air Using Designated Reference ro Class I Equivalent Methods*.

Filter media can be purchased from Tisch Environmental:

**PART NUMBER: Tisch Brand SF17138 for 60/pack of filters, Whatman brand TE-7592-104 and MTL brand TE-PT47AN 50/pack.**

The filters should be inspected prior to use for:

- Holes or damage
- Discoloration
- Loose media on the filter
- Non-uniformity of the filter

The filter cassette is detailed in 40CFR Part 50 Appendix L. The filter cassette is made up of the following USEPA specified components:

L-27 Filter Cassette Upper Section

L-28 Screen

L-29 Filter Cassette Lower Section

The filter cassette can be purchased from Tisch Environmental:

**PART NUMBER: TE-FH47**

The filter cassette comes with a protective case and an anti-static bag and is assembled as follows:

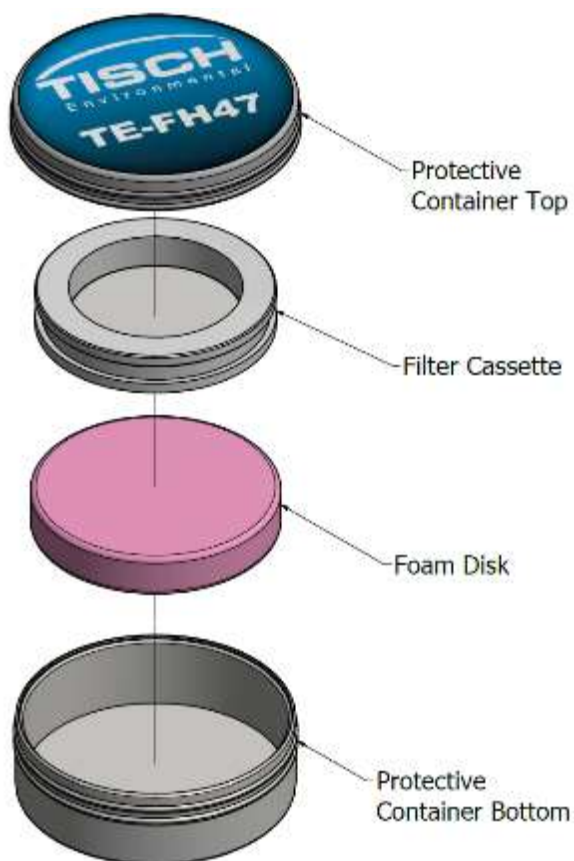

## 4.7 Lot, Field and Lab Blanks

### Lot Blanks

Lot blanks are clean, unexposed filters that are used to determine the filter weight stability over a long period of time. Lot blanks are (3) filters selected from a single shipment of filters from a supplier. Lot blanks are conditioned for an initial 24 hours prior to the initial pre-weight determination. The (3) filters are then reweighed periodically (daily or weekly) and stored in the conditioning chamber with the other filters from the lot between being weighed.

This weighing of lot blanks should continue until the weekly weight change of the filters is less than 15µg. This determines the period of time a filter lot should be conditioned before it can be used for routine sampling.

### Field Blanks

Field blanks are conditioned, weighed and clean unexposed filters that are used to determine if contamination occurs during sample setup, recovery and transport. Field blanks occur at 10% of the sampler's operating routine. Field blanks should be scheduled to ensure that a post weighing session contains 10% of blanks or at least (1) field blank.

Field blanks are taken out to the sampler, removed from their protective container and installed into the filter holder like a normal sample is. They are left there momentarily (a minute or two) then removed and placed back into their protective container. They are then left in the sampler's enclosure while the sampler is running a sample. Field blanks are retrieved along with the sample and weighed in the lab to determine if any contamination occurs in the field.

### Lab Blanks

Lab blanks are clean, conditioned filters that are used to determine if any contamination or weight change is happening in the pre and post weighing functions in the laboratory. Laboratory blanks should be kept inside the conditioning chamber except during weighing. Each post-weighing session should include at least one laboratory blank. If the weight of the laboratory blank changes more than 15 $\mu$ g, there is contamination of the filters during the weighing process that need to be investigated and resolved.

## 4.8 Filter Pre-Conditioning and Weighing

NOTE: For PM<sub>10</sub> and PM<sub>2.5</sub> sampling, refer to *EPA QA Guidance Document 2.12 – Monitoring PM<sub>2.5</sub> in Ambient Air Using Designated Reference for Class I Equivalent Methods* for information on filter weighing, conditioning and microbalance standards.

### Conditioning of clean unexposed filters

New, unexposed filters must be conditioned in a conditioning environment for 24 hours before the pre-weighing. The mean %RH must be between 30 and 40 %RH  $\pm$ 5% over the 24 hours of conditioning and a mean temperature between 20 and 23°C with a variability of no more than  $\pm$ 2°C over the 24 hour conditioning period.

In the conditioning chamber the filter should be placed on a covered rack or an open-sided cabinet that will allow circulation over the filters while reducing the chance that airborne particulates will get onto the filters.



Take care that other filter media in the chamber does not contaminate the filters such as quartz and glass filter fibers. Filters should be conditioned in their filter-handling container such as a slide petri dish. Write the filter's unique filter ID onto the container's label. During conditioning, place the lid so it partially covers the open container.

Ensure with the use of lot blanks that the filter lot does not exhibit weight loss of more than 15 $\mu$ g per week.

#### **Pre-weighing of unexposed filters**

The filters must be weighed in the same room as they were conditioned in. Record the %RH and temperature and verify the mean temperature and %RH for the last 24 hours has remained between 20-23°C (with instantaneous readings within  $\pm 2^\circ\text{C}$ ) and 30-40% RH (with instantaneous readings within  $\pm 5\%$  RH).

Using clean forceps two working mass reference standards must be weighed as a QC check such as 100mg and 200mg. Record these weights. If these weights disagree by more than 3 $\mu$ g from their actual weight, they must be reweighed.

Weigh enough laboratory blanks to provide at least 10% or at least one laboratory blank during the post sampling weighing session. Also, weigh enough field blanks to meet 10% or at least one field blank during the post weighing session.

Weigh each filter on the microbalance. Follow the microbalance manufacturer's operations manual for proper operation of the microbalance. The filters should be handled with forceps and only held by the right. Pass the filter, support ring side up near an antistatic strip for 60 seconds before weighing. Immediately transfer the filter to the microbalance for weighing. Record the filter ID, lot number and tare-weight (pre-weight).

After every 10 filters, reweigh one of the standards and record the data. These standards should be within 3 $\mu$ g. Also reweigh one of the 10 filters. It must be within 15 $\mu$ g of its original weight.

After all the filters are weighed, both working standards should be reweighed and must be within 3 $\mu$ g of their standard. Also one random filter of the total should be reweighed and it must be within 15 $\mu$ g of its original weight.

**NOTE:** Any unexposed filter whose weight is outside the range of the manufacturer's specifications should be discarded and investigated as to why.

Check the filter cassettes for cracks, evidence of wear, dirt and contamination. Cassettes can be cleaned in the dishwasher and rinsed with deionized water. Thoroughly dry the cassette before use. Filters must be used within 30 days of being pre-weighed. Install each filter into the filter cassette and place the cassette into its protective container and then into an antistatic bag for field transport and use.

## 4.9 Field Sample Handling

Remove the filter cassette from the antistatic bag and protective tin. Ensure the filter holder is open and place the filter cassette with filter into the filter holder. Close the filter holder and set the sampler for the appropriate sample date and time. At the completion of the sampling event, the filter must be collected within 4 days (96 hours) of the end of the run. The filter cassette should be carefully removed from the filter holder, placed into the protective tin with the particulate side upwards and then placed in an anti-static bag.

**NOTE:** The filter should never be touched. When handling the cassettes, make sure your hands are clean and if gloves are worn, ensure they are anti-static and powder-free.

Place the filter cassettes (in the tins and anti-static bags) into an insulated container such as a small cooler for storage. Use 'blue-ice' packs or frozen gel packs to achieve temperatures below 4°C. Place a small min/max recording thermometer into the cooler to verify that the samples remained cool during transport to the laboratory.

The sample must be placed back into the conditioned laboratory and weighed within 10 days if stored below 25°C. If stored below 4°C, it is 30 days from the end of the run that the filter must be placed back into the laboratory and weighed.

**NOTE:** Any filter that is noticeably torn or has a hole in it should immediately be invalidated and investigated on what caused the problem.

## 4.10 Filter Post-Conditioning and Weighing

NOTE: For PM<sub>10</sub> and PM<sub>2.5</sub> sampling, refer to *EPA QA Guidance Document 2.12 – Monitoring PM<sub>2.5</sub> in Ambient Air Using Designated Reference for Class I Equivalent Methods* for information on filter weighing, conditioning and microbalance standards.

### Conditioning of exposed filters

The lab technician who receives and logs in the sample shipment must verify that the shipment was maintained at below 25°C for less than 10 days or less than 4°C for less than 30 days of the filters being in the field.

The lab technician will also receive the data recorded from all the site samplers and any paperwork relating to the sample.

Remove the filter cassette containers from the cooler / freezer and allow each filter cassette container to warm to room temperature. After the containers warm to room temperature open each container to begin the filter equilibration process. During conditioning place the lid of the container partially over the opening so it is partially open. Inspect for any tears, holes or anomalies of the filter that may have occurred during sampling and note this and flag it for further analysis.

### Using the Filter Cassette Removal Tool (TE-W-400)

Place the filter cassette removal tool on a flat surface. Grab the filter cassette and push into the opening carefully.

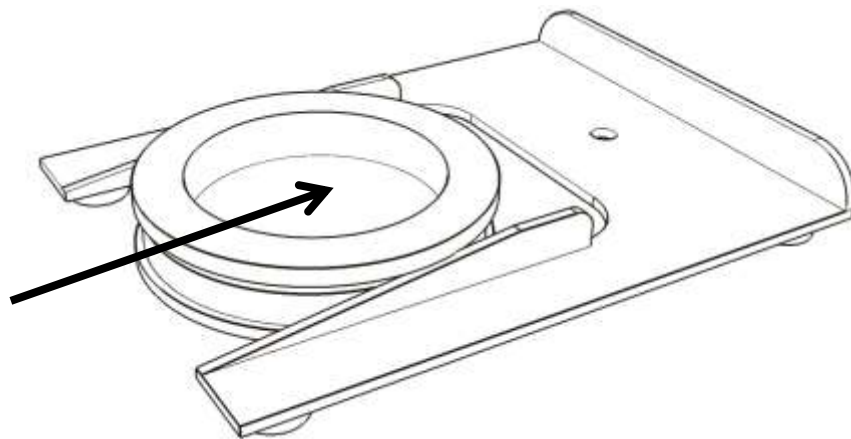



This will separate the top and bottom halves of the filter cassette.

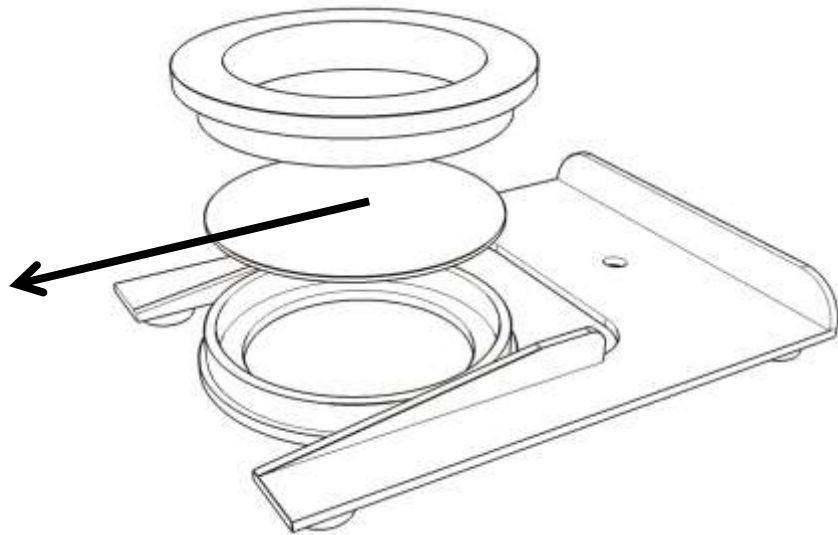

Remove the filter carefully with forceps being careful to only handle the filter by the ring. Place the filter with the dirty-side up into a filter-handling container or petri dish with the corresponding filter ID.

Remove the cassettes and screens from the conditioning area to another area for cleaning.

Allow the filters to condition for at least 24 hours.

#### **Weighing of exposed filters**

The filters must be weighed in the same room as they were conditioned in. Record the %RH and temperature and verify the mean temperature and %RH for the last 24 hours has remained between 20-23°C (with instantaneous readings within  $\pm 2^\circ\text{C}$ ) and 30-40% RH (with instantaneous readings within  $\pm 5\%$  RH).

Using clean forceps two working mass reference standards must be weighed as a QC check such as 100mg and 200mg. Record these weights. If these disagree by more than 3 $\mu\text{g}$  they must be reweighed.

Weigh enough laboratory blanks to provide at least 10% or at least one laboratory blank during the post sampling weighing session. Also, weigh enough field blanks to meet 10% or at least one field blank during the post weighing session.

Weigh each filter on the microbalance. Follow the microbalance manufacturer’s operations manual for proper operation of the microbalance. The filters should be handled with forceps and only held by the support ring. Pass the filter, support ring side up near an antistatic strip for 60 seconds before weighing. Immediately transfer the filter to the microbalance for weighing. Record the filter ID, lot number and tare-weight (pre-weight).

After every 10 filters, reweigh one of the standards and record the data. These standards should be within 3µg. Also reweigh one of the 10 filters. It must be within 15µg of its original weight.

After all the filters are weighed, both working standards should be reweighed and must be within 3µg of their standard. Also one random filter of the total should be reweighed and it must be within 15µg of its original weight.

#### 4.11 Calculating Mass Concentrations

The total sample volume can be calculated from the sample which is located on the sample completed screen. If the total volume is not available it can be calculated using the following formula:

$$V_a = \frac{(Q_{avg})(T)}{16.67}$$

Where:  $V_a$  = total sample volume (m<sup>3</sup>)  
 $Q_{avg}$  = average sample flow rate (Lpm)  
 $T$  = total sample time (hours)  
 16.67 = conversion to m<sup>3</sup>/hr

Using the pre and post sample filter weights, the total filter mass gain can be found by the following formula:

$$M_{delta} = (M_{post} - M_{pre})$$

Where:  $M_{delta}$  = total mass gained during sampling in µg  
 $M_{post}$  = post sample weight in µg  
 $M_{pre}$  = pre sample weight in µg

The total concentration of particulate can then be calculated using the following formula:

$$PM_x = \frac{M_{final}}{V_a}$$

Where:  $PM_x$  = concentration of  $PM_{2.5}$  or  $PM_{10}$  particulates in  $\mu\text{g}/\text{m}^3$   
 $V_a$  = total volume of the sample

## 4.12 Data Validation

The sample run data should be verified by the following criteria:

- Average volumetric flow rate = 16.7 L/min  $\pm$  5%.
- Flow rate coefficient of variation less than 4%.
- Temperature difference (filter – ambient) less than 5°C.
- Sample Time is greater than 23 hours and less than 25 hours.
- Verify that the sample data sheet the technician filled out does not indicate an invalid sample or that there were warnings or alarms during the sample.
- Verify that the sample was retrieved within 4 days (96 hours) of the completion of the sample run.
- Verify that the container holding the filters did not exceed 25°C during transport to the laboratory.
- Verify that filter was used within 30 days if kept at 4°C or below, or 10 days if kept below 25°C.
- Verify that the barometric pressure, filter temperature and ambient temperature were reading appropriately on the datalog and were not out of specifications or varied widely throughout the sample.
- Verify that there were not more than 10 power losses during the sample period or any other alarms that would invalidate the sample.

## 5.0 PM<sub>10</sub> Inlet / PM<sub>2.5</sub> Cyclone

This section describes the TE-PM10 inlet and the TE-PM2.5C PM<sub>2.5</sub> cyclone fractionator.

### 5.1 TE-PM10 Inlet

The TE-PM10 inlet is a 10 micron particulate fractionator. Below is a cut-away view of the TE-PM10.

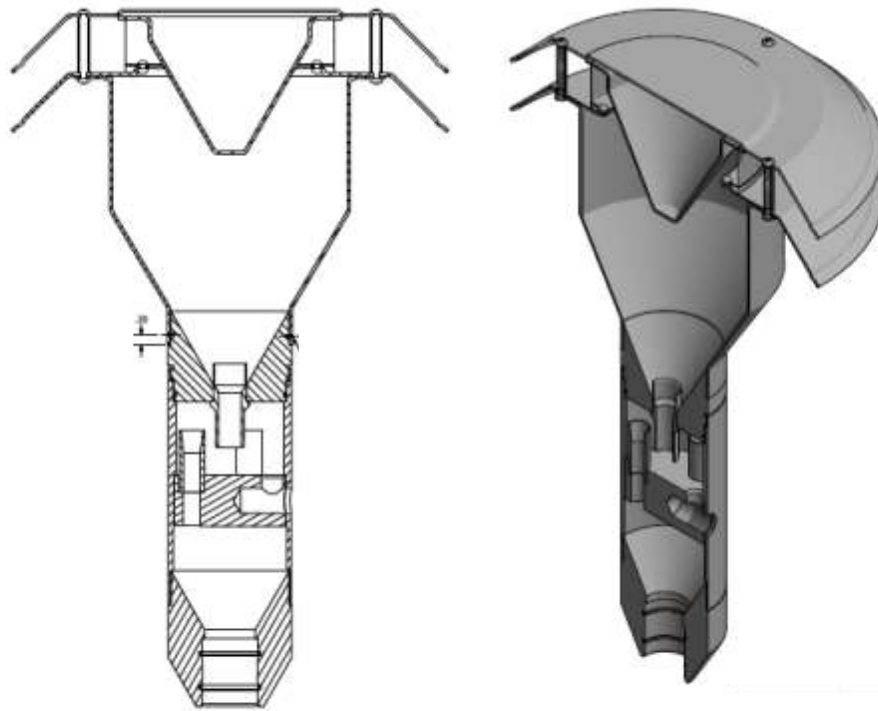

Ambient air is pulled in through the top of the inlet and particles that have aerodynamic diameters greater than 10um are impacted on the inside plate of the unit. The particles that have less than 10um of aerodynamic diameter are expelled at the bottom, onto the next stage.

The following shows the airflow path through the TE-PM10 Inlet.

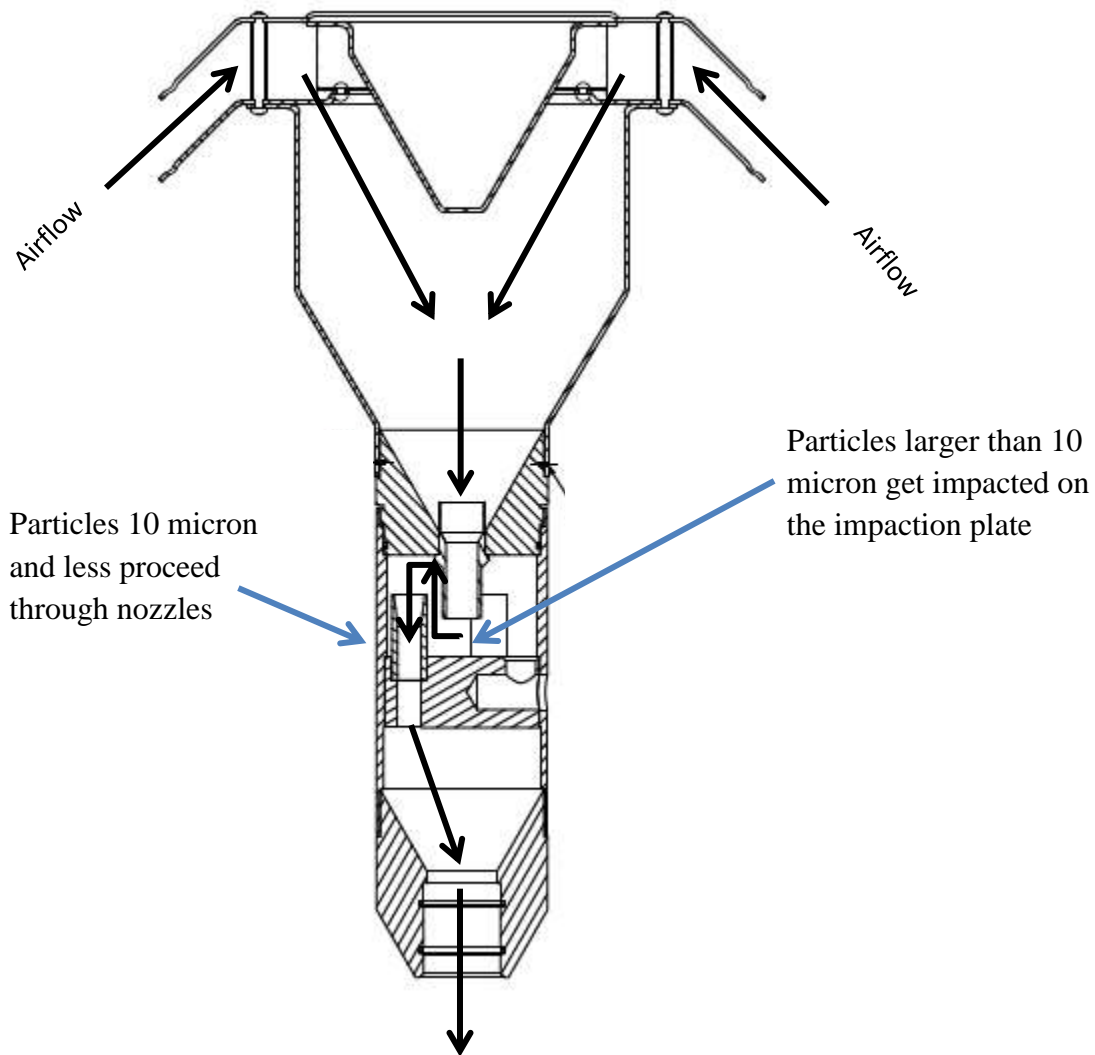

## 5.2 Cleaning the PM<sub>10</sub> Inlet

USEPA *Quality Assurance Guidance Document 2.12, Monitoring PM<sub>2.5</sub> in Ambient Air Using Designated Reference or Class I Equivalent Methods* suggests the PM<sub>10</sub> inlet must be cleaned every 4 weeks. To clean the TE-PM10 Inlet, perform the following:

1. Remove the glass jar and empty any water.
2. Place the jar aside.
3. Remove the PM<sub>10</sub> inlet from the sampler and place on flat surface.
4. Unscrew the lower piece from the upper piece.
5. Using cotton swabs, q-tips and distilled water or general purpose cleaner, clean the impactor plate and the nozzles.

6. Using a soft brush, cloth and cotton swabs, lightly scrub all interior surfaces and the bug screen with distilled water and / or general purpose cleaner.
7. Check the o-ring around the upper unit that seals the upper and lower pieces for wear and damage. Replace if worn or damaged
8. Check the 2 o-rings in the bottom of the inlet for wear and damage. Replace if worn or damaged.
9. Place a small amount of o-ring grease around the o-ring that seals the upper and lower units.
10. Screw the upper and lower unit back together carefully.
11. Place a small amount of o-ring grease around the 2 o-rings on the bottom.
12. Screw the jar back into the inlet and place the inlet back onto the downtube.

The PM<sub>10</sub> Inlet has the following O-rings that should be inspected for wear and replaced as needed.

Quantity	Description	Part Number
2	Exit Adapter O-Rings	TE-W-022
1	Impactor Nozzle O-Ring	TE-W-023
2	Downtube O-Rings	TE-W-021

These can also be ordered together in a kit by part number TE-W-020.

There are also O-rings located in the black downtube adapter and those can be ordered using part number TE-W-024.

### 5.3 TE-PM2.5C Cyclone

The TE-PM2.5C is a PM<sub>2.5</sub> particle fractionator that utilizes a cyclonic effect to separate ambient particles that have an aerodynamic diameter less than 2.5um. The cyclone is placed directly underneath the PM<sub>10</sub> inlet to achieve PM<sub>2.5</sub> collection.

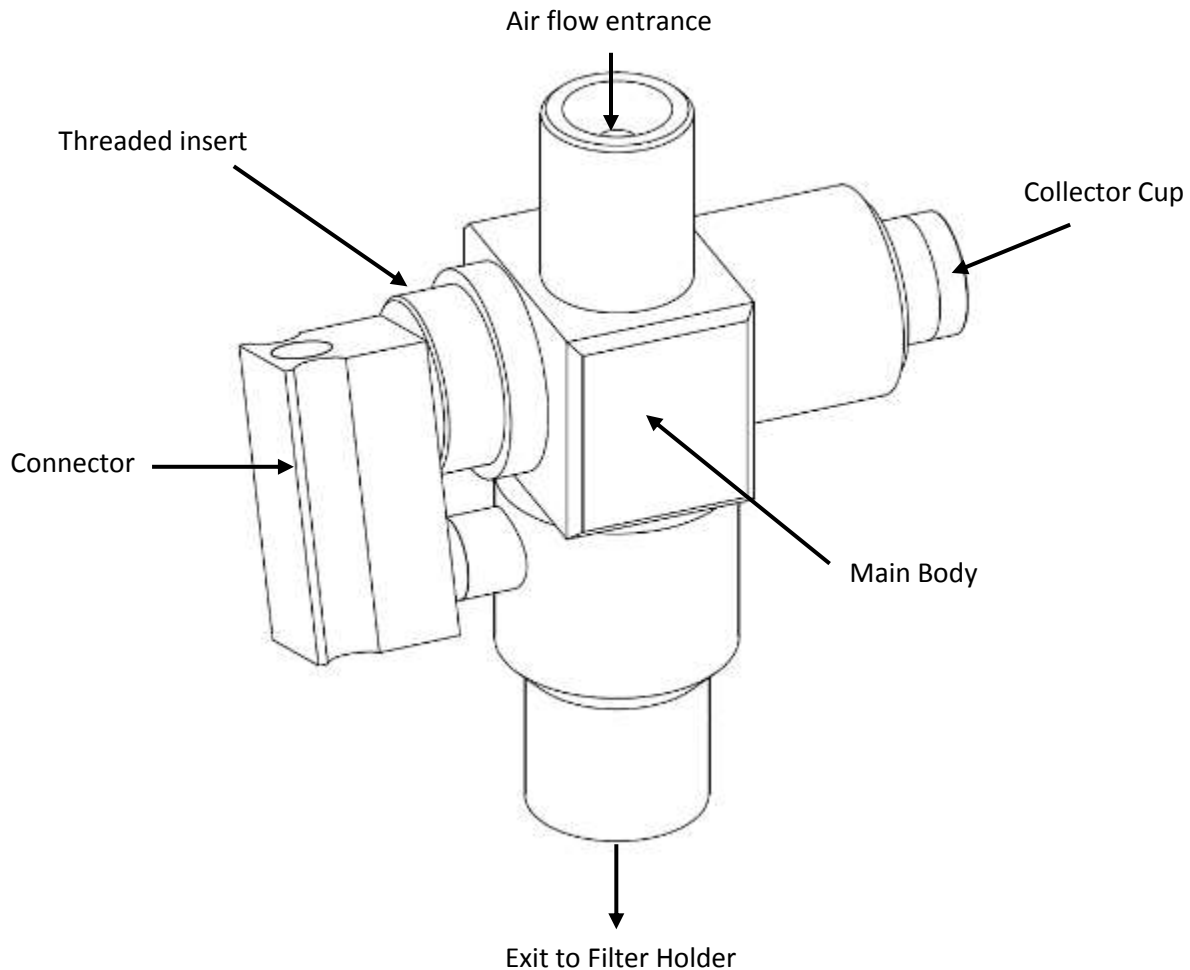

## 5.4 Cleaning the TE-PM2.5C Cyclone

The following describes how to clean the TE-PM2.5C Cyclone.

1. Remove the cyclone from the sampler by pulling the downtube up and pulling the cyclone off of the top of the filter holder.
2. Place on a flat surface.
3. Unscrew the collector cup and wipe out the inner body with a lint-free laboratory wipe. Distilled water or general purpose cleaner can be used if the inner body is very dirty.
4. Wipe the inside of the collector with a lint-free wipe.
5. Remove the connector by pulling outward.
6. Inspect the o-rings, on the tubes that the connector plugs into, for wear or damage. Replace if worn or damaged.
7. Wipe down the connector and the outside of the tubes.

8. Unscrew the threaded insert.
9. Wipe down the threaded insert and the inside of the body where it inserts into with a lint-free laboratory wipe.
10. Inspect the o-ring on the outer lip of the threaded insert for wear or damage. Replace if worn or damaged.
11. Thread the threaded insert back into the cyclone body.
12. Place a small amount of o-ring grease around the o-rings on the connector tubes.
13. Push the connector onto the tubes.
14. Thread the collector cup back into the body.
15. Wipe out the bottom exit of the cyclone with a lint-free wipe.
16. Place back onto filter holder and push downtube back onto top of cyclone.
17. Ensure to place the PM<sub>10</sub> inlet back onto unit prior to sampling.

The TE-PM2.5C Fractionator has the following O-rings that should be inspected for wear and replaced as needed.

Quantity	Description	Part Number
2	Exit Nozzle O-Rings	TE-W-031
1	Collector Cup O-Ring	TE-W-032
1	Threaded Insert O-Ring	TE-W-033
2	Connector tube O-Rings	TE-W-034
2	Stainless steel bolt O-Rings	TE-W-035

These can also be ordered together in a kit by part number TE-W-030.

## 5.5 Placing of the Cyclone and PM<sub>10</sub> Head

To sample for PM<sub>10</sub> you would install the downtube onto the top of the filter holder and then the TE-PM10 head onto the top of the downtube.

To sample for PM<sub>2.5</sub> you would install the TE-PM2.5C onto the top of the filter holder, then the downtube and lastly the TE-PM10 head on top of the downtube.

**NOTE:** The downtube adapter has o-rings inside of it to prevent water from entering the enclosure. Ensure these o-rings are greased when removing and installing the downtube.



## 6.0 Sample Setup

The sample setup menu allows you to setup the sampler to run on standard US EPA schedules for 1 in 3 day sampling, 1 in 6 day sampling and 1 in 12 day sampling for 24 hours, midnight to midnight. Also, a custom sample can be setup that will start and stop the sampler at a specific date and time.

### 6.1 Site and Filter ID

The Site ID and Filter ID can be entered by pressing the ‘Enter Filter and Site ID’ button located in the Sample Setup Menu. The Site ID and Filter ID can be up to a 10 digit number, with no alpha-numerical characters allowed.



Filter and Site ID Screen

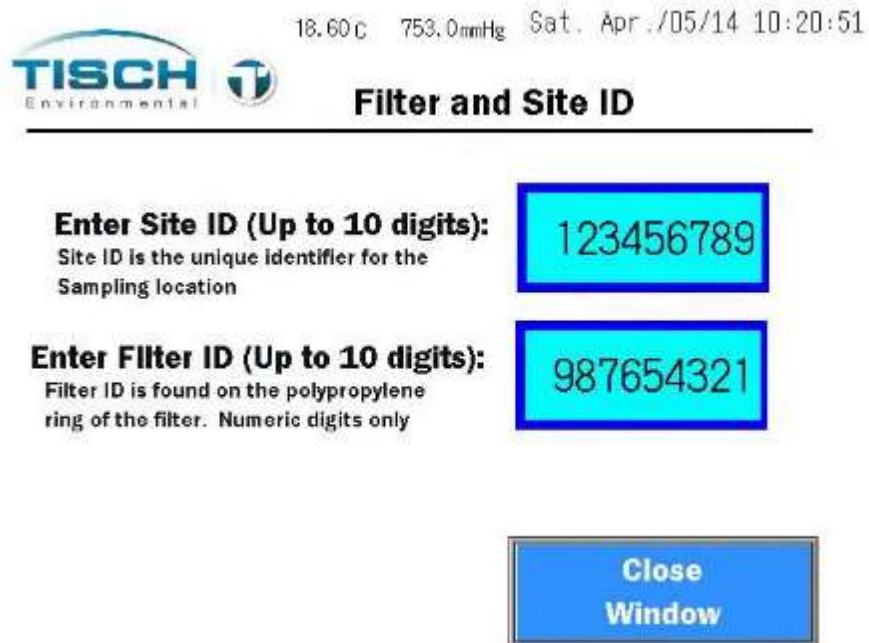

### 6.2 USEPA Sample Setup

The USEPA standard schedules of a 1 in 3, 1 in 6, or 1 in 12 day sample schedule can be easily programmed in the sample setup menu. This example uses the 1 in 3 day schedule. To setup a 1 in 6 or 1 in 12 the procedure is the same. When setting up an USEPA sample, the system is color coded to somewhat match the US EPA schedule found at:

<http://www.epa.gov/ttnamti1/calendar.html>.

The 1 in 12 schedule will be shown purple, The 1 in 6 will be shown in green and the 1 in 3 sample schedule will be shown in orange.

The 1 in 3 sample setup is found here:

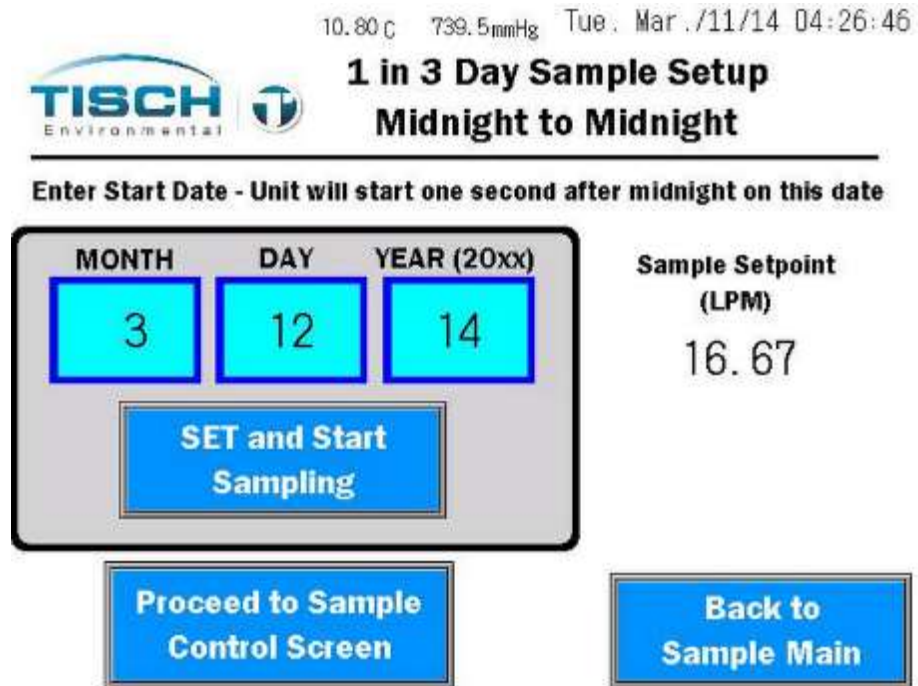

On this screen you have the ability to set a start Month / Day / Year. The system will not allow you to enter a date in the past.

The unit will start on Midnight of the day you enter. So if you enter 2/23/14 and the date is 2/22/14 and the time is 23:59:59, in one second the unit will turn on and sample for 24 hours midnight to midnight.

You also see the setpoint of the sample. This defaults to 16.67 Lpm which is the designed setpoint, so this value should never be changed. See Screen Maintenance section 8.0 to change the setpoint.

After the sample is setup press the **PROCEED TO SAMPLE CONTROL SCREEN** button.

Sample control screen

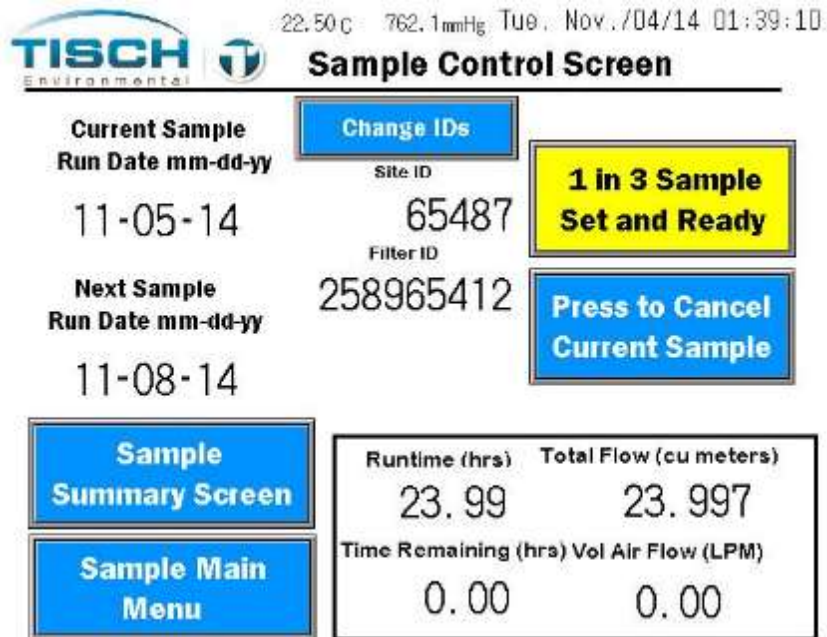

22.50 C 762.1 mmHg Tue, Nov. /04/14 01:39:10

**TISCH Environmental** **Sample Control Screen**

**Current Sample**  
Run Date mm-dd-yy  
11-05-14

**Next Sample**  
Run Date mm-dd-yy  
11-08-14

**Change IDs**  
Site ID  
65487  
Filter ID  
258965412

**1 in 3 Sample Set and Ready**

**Press to Cancel Current Sample**

**Sample Summary Screen**

**Sample Main Menu**

Runtime (hrs)	Total Flow (cu meters)
23.99	23.997
Time Remaining (hrs)	Vol Air Flow (LPM)
0.00	0.00

On this screen you have the ability to Cancel the current sample and see all the pertinent sample runtime information such as:

- Current Sample Run Date** This is the date that the sampler will start running at midnight.
- Next Sample Run Date** This is the date of the next sample. If the current start date is 2/23/14 and you are running a 1 in 3 schedule, the next sample run date will be 2/26/14.
- Runtime** This is the actual runtime of the sample. When the sample starts this value is reset to zero. The currently displayed value is the last sample's runtime or the current runtime if the sampler is running.
- Time Remaining** This is the time remaining of the current sample. When a 24 hour sample starts this value will be 24.
- Total Flow** This is the total airflow in cubic meters. At 16.67 Liters per minute, 1 cubic meter per hour of air will pass through the sampler. In 24 hours, approximately 24 cubic meters of air will flow through the sampler.
- Vol Air Flow** This is the actual volumetric flow in Lpm.

The **SAMPLE SUMMARY SCREEN** button will take you to the sample summary screen

Sample summary screen

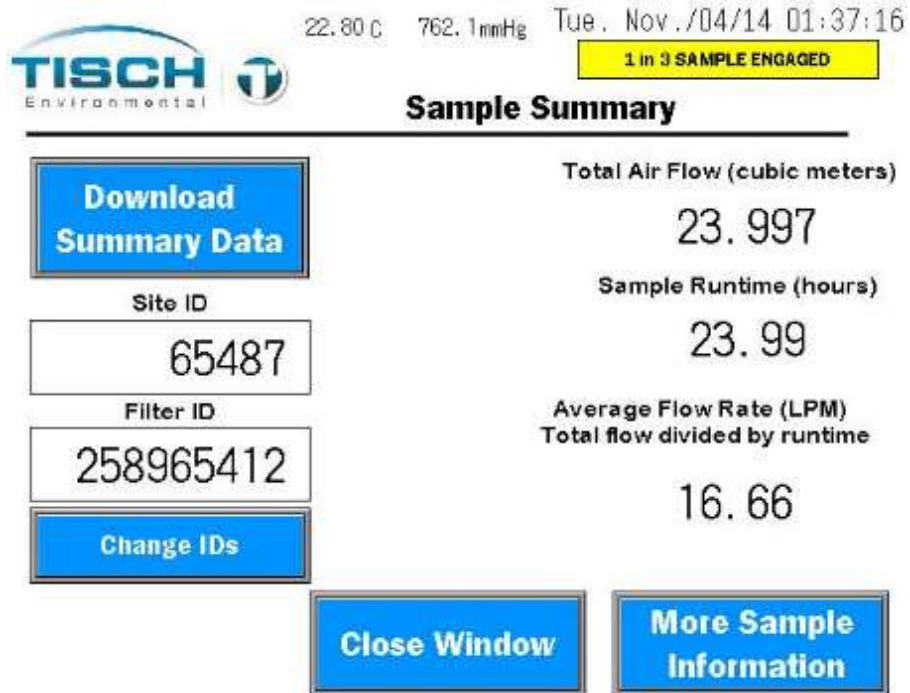

22.80 C 762.1mmHg Tue. Nov./04/14 01:37:16  
**1 in 3 SAMPLE ENGAGED**

**Sample Summary**

<p><b>Download Summary Data</b></p> <p>Site ID</p> <p>65487</p> <p>Filter ID</p> <p>258965412</p> <p><b>Change IDs</b></p>	<p>Total Air Flow (cubic meters)</p> <p>23.997</p>
	<p>Sample Runtime (hours)</p> <p>23.99</p>
	<p>Average Flow Rate (LPM) Total flow divided by runtime</p> <p>16.66</p>
	<p><b>Close Window</b>      <b>More Sample Information</b></p>

This screen is what appears after a successful sample. The last sample completed screen is a summary of the sample and gives the operator all the pertinent information for the sample such as total air flow, runtime and average flow rate.

**NOTE:** When a sample is setup to run (Engaged) there will be an indication on every screen at the top. When a sample is running there will also be an indication at the top of each screen.

**NOTE:** When a sample is running, all features such as changing the date and time, doing a calibration or leak check are disabled. The sample must be canceled if those are necessary.

Press the **MORE SAMPLE INFORMATION** to see more information about the sample that has just completed.

More Sample Information Screen

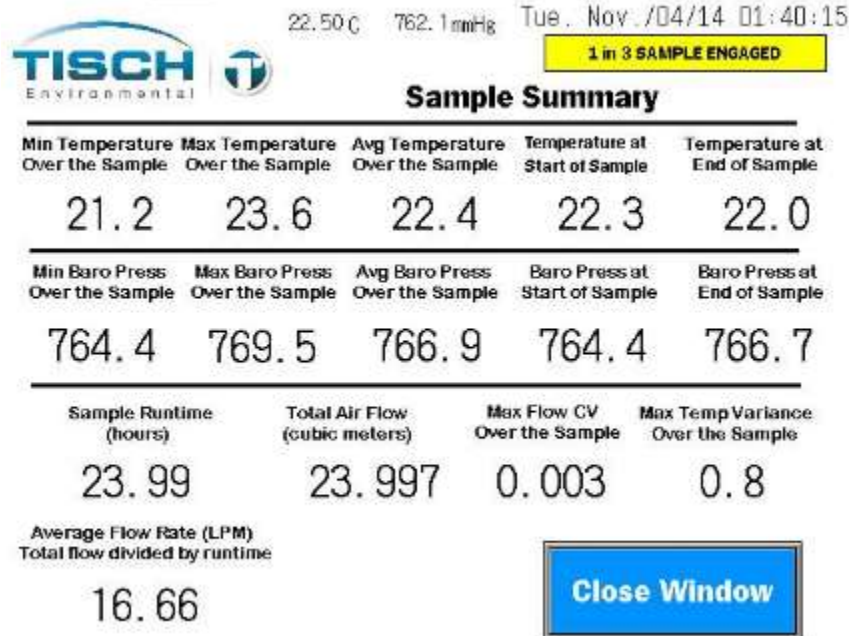

22.50 C 762.1 mmHg Tue. Nov. /04/14 01:40:15  
**1 in 3 SAMPLE ENGAGED**

**Sample Summary**

Min Temperature Over the Sample	Max Temperature Over the Sample	Avg Temperature Over the Sample	Temperature at Start of Sample	Temperature at End of Sample
21.2	23.6	22.4	22.3	22.0
Min Baro Press Over the Sample	Max Baro Press Over the Sample	Avg Baro Press Over the Sample	Baro Press at Start of Sample	Baro Press at End of Sample
764.4	769.5	766.9	764.4	766.7
Sample Runtime (hours)	Total Air Flow (cubic meters)	Max Flow CV Over the Sample	Max Temp Variance Over the Sample	
23.99	23.997	0.003	0.8	
Average Flow Rate (LPM) Total flow divided by runtime				
16.66				

**Close Window**

On the more sample information screen the following information is presented to the operator:

- Min / Max / Avg Temperature** This is the minimum, maximum and average ambient temperature over the entire sample period in degrees Celsius.
- Temperature at Start of Sample** This is the ambient temperature at the start of the sample in degrees Celsius.
- Temperature at End of Sample** This is the ambient temperature at the end of the sample in degrees Celsius.
- Min / Max / Avg Baro Press** This is the minimum, maximum and average barometric pressure over the entire sample period in mmHg.
- Baro Press at Start of Sample** This is the barometric pressure at the start of the sample in mmHg.
- Baro Press at End of Sample** This is the barometric pressure at the end of the sample in mmHg.
- Max Flow CV** This is the maximum flow coefficient of variance over the entire sample.

**Max Temp Variance** This is the maximum temperature variance between ambient and the filter temperature in degrees Celsius.

**Runtime** This is the actual runtime of the sample. When the sample starts this value is reset to zero.

**Total Flow** This is the total airflow in cubic meters. At 16.67 Liters per minute, 1 cubic meter per hour of air will pass through the sampler. In 24 hours it should be 24 cubic meters.

**Average Flow Rate** This is the total flow in Lpm divided by the runtime to derive the average flowrate over the sample period.

### 6.3 Custom Sample

A custom sample can be setup that allows the operator to enter a start Month / Day / Year / Hour / Minute and duration in Hours / Minutes. The sampler will start on the date entered and run for the duration of the runtime entered. The system does not allow the user to enter a date in the past.

The custom sample can be found here:



All alarms associated with shutting down a sample, datalogging and all features of the USEPA standard samples are associated with the custom sample.

When a custom sample is engaged, all screens will show a blue box indicating that a custom sample has been setup and engaged. When a custom sample is running a green box will show on all screens that a sample is running.

**NOTE:** Once a custom sample stops, it will not reoccur. It is a one-time sample.

### 6.4 Canceling a Sample

To cancel a sample, press the PRESS TO CANCEL CURRENT SAMPLE button located on the sample control screen. A popup will appear asking if you are sure you would like to cancel the current sample. Press YES to cancel or NO to return to the sample control screen.



**NOTE:** Once a sample is canceled, it must be setup again in the sample setup menu. If the sampler is set for a 1 in x sample schedule and the sample is canceled, the 1 in x sample schedule must be reconfigured in order for the sampler to run again.

**NOTE:** If the sampler is set for a 1 in x sample and the date is changed to the future, the sample will be automatically cancelled and must be setup again. Also, if there is an extended power fail and if the 1 in x sample is missed, it will cancel the sample and the sample must be setup again.

## 6.5 Sample Alarms

When a sample is running, there are certain events, or alarms, that will shut down a sample per USEPA specifications. There are also events that do not shut down the sample, but will be logged in the history log and are called Warnings.

When an alarm shuts down the sample, the history log will automatically appear alerting the operator that there has been an alarm and the sample has been shut down.

The following alarms will shut down a sample:

### Shutdown Sample Alarms

<b>Flow</b>	Alarms when flowmeter is unplugged, goes over range (25 Lpm) or the electronics detects an internal problem with the sensor.
<b>Barometric Pressure</b>	Alarms when barometric pressure board is unplugged, if the pressure falls below 550mmHg, the pressure goes above 850mmHg or if the electronics detects an internal problem with the sensor.
<b>Ambient Temperature</b>	Alarms when the temperature drops below -90 Degrees Celsius, goes above 60 Degrees Celsius, is unplugged or the electronics detect an internal problem with the sensor.
<b>Filter Temperature</b>	Alarms when the temperature drops below -90 Degrees Celsius, goes above 60 Degrees Celsius, is unplugged or the electronics detect an internal problem with the sensor.



- 10% Flow Variance**      When a sample is running and the flow varies by 10% or more for 10 minutes, the sample will shut down.
  
- High System Pressure**      When the internal pressure of the system exceeds 200 inches of H<sub>2</sub>O it will shut down the sample and alarm.
  
- 10 Power Failures**      When a sample is running and 10 consecutive power fails occur, it will shut down the sample and active the alarm.

There are also warnings associated with a sample. A warning will not shut down the sample and will allow the sample to complete. A warning will alert the operator that a warning has occurred and to check the history log.

**Warnings that do not shut down a sample**

---

- 5% flow variance**      When a sample is running and the flow varies by 5% or more for 5 minutes, the system will log the event in the history log.
  
- Power Failure**      A power fail will be logged in the history log.
  
- Sample Time**      When a sample completes and the sample runtime is less than 23 hours or more than 25 hours it will log the event in the history log.
  
- Temperature Variance**      If the ambient temperature and the filter temperature vary by more than 5 Deg C for 30 minutes.

**NOTE:** When a warning appears on the screen and is logged in the history log it must be acknowledged. If it is not acknowledged by the operator it will continue to be active in the history log and will continue to show on the sample completed screen.



## 6.6 More Sampling Information

The TE-Wilbur system has the ability to store the last (5) samples that occurred into the system. The oldest sample will be number 5 and the newest sample will be number 1. The oldest will get discarded as a new sample has completed. This information is updated after the sample has completed and can be found by the following keystrokes:



## 6.7 Other Sampling Features

When a sample has started, the following features are disabled:

- Maintenance Menu
- System Calibration Menu
- Perform Leak Checks Menu

If the operator is performing a calibration, leak check or is running the system in manual mode, those will be terminated and the sample will take precedence and will start automatically.

When a sample is started, the sample control screen is automatically displayed.

When a sample is completed, the sample completed summary screen will be automatically displayed.

When a power fail occurs, on re-power the sampler will start sampling again as long as the sample time is within the time the operator has set it to.

## 7.0 Calibration

The Calibration menu is where the sensors for flow measurement, ambient temperature, filter temperature and barometric pressure can be verified and calibrated.

### 7.1 Ambient Temperature Calibration

The ambient temperature sensor is a highly accurate PT100 RTD (resistive temperature device). The ambient temperature sensor can be found inside the radiation shield, which is bolted to the left side of the enclosure.

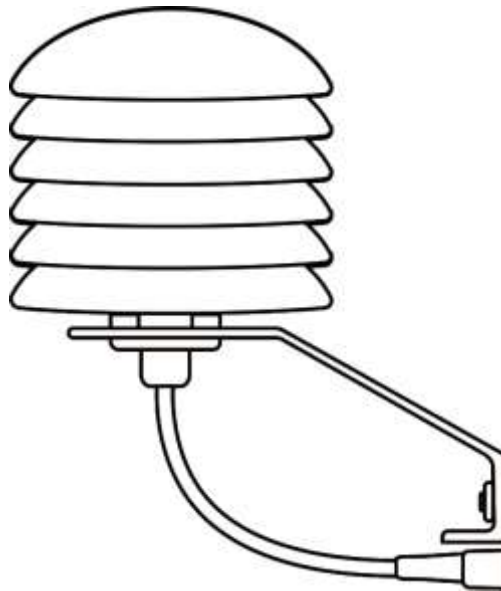

To calibrate the ambient temperature sensor perform the following:

1. Obtain a calibrated temperature device such as the Tisch FRM-CAL low volume calibration system.
2. Allow the calibrated temperature device to reach equilibrium with the ambient air and take a reading on the calibrated temperature device.
3. The temperature calibration can be performed by following these keystrokes:



4. Press the box and enter the temperature reading from the calibrator.
5. Press UPDATE to update the temperature.

Ambient Temperature Calibration Screen

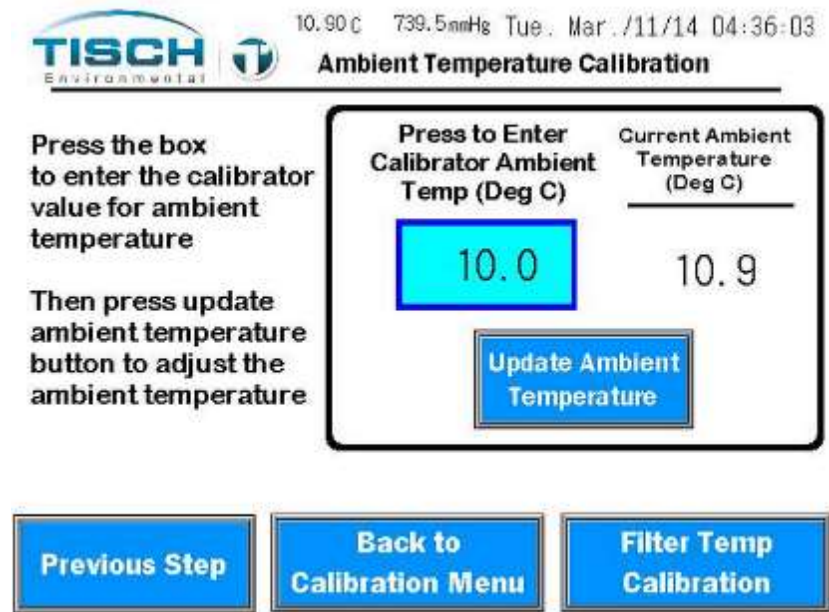

## 7.2 Filter Temperature Calibration

The Filter temperature sensor is a highly accurate PT100 RTD (resistive temperature device). The filter temperature sensor can be found inside the filter temperature thermo well which is on the front of the filter holder. The filter temperature RTD can be removed and inserted from the thermo well by screwing and unscrewing it. The thermo well is secured tightly into the filter holder body and provides a sealed fitting. Tightening the RTD into the thermo well is not important to seal the system so it can be tightened finger-tight into the thermowell.

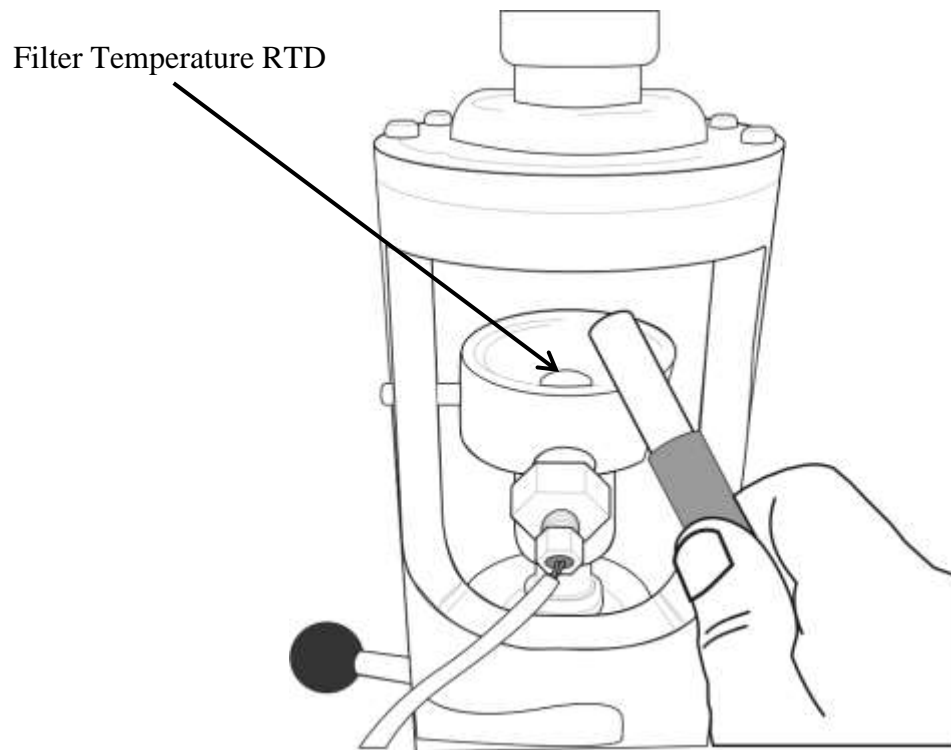

To calibrate the filter temperature sensor perform the following:

1. Obtain a calibrated temperature device such as the Tisch FRM-CAL low volume calibrator.
2. Allow the calibrated temperature device to reach equilibrium with the ambient air.
3. Place the temperature device into the filter holder holding it at the tip of the filter temperature RTD.
4. The temperature calibration can be performed by following these keystrokes:



5. Press the box and enter the temperature reading from the calibrator.
6. Press UPDATE to update the temperature.

Filter Temperature Calibration Screen

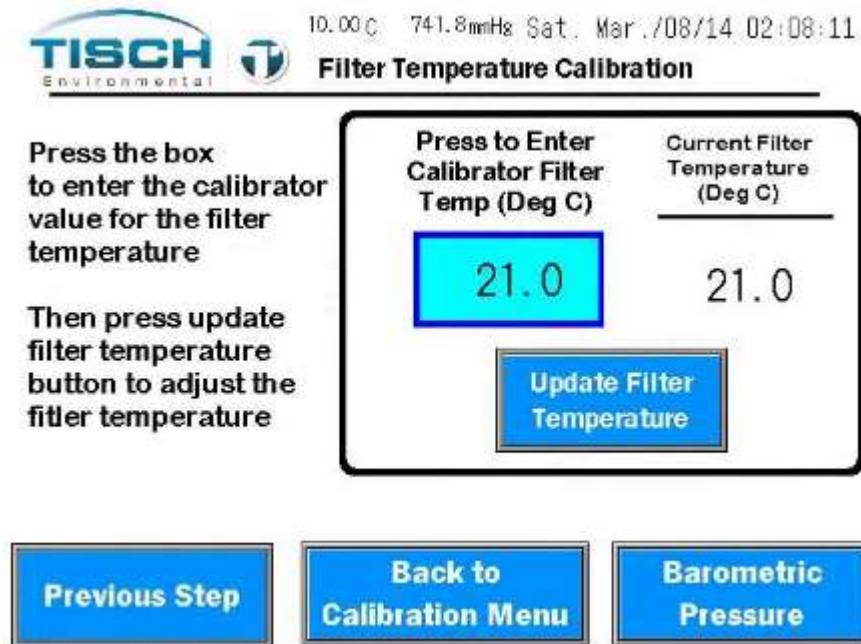

### 7.3 Barometric Pressure Calibration

The barometric pressure sensor is a highly accurate electronic sensor that is mounted inside the enclosure. Since pressure is equalized from inside the enclosure to outside the enclosure, measuring the barometric pressure outside of the enclosure will suffice.

To calibrate the barometric sensor perform the following:

1. Obtain a calibrated barometric device such as the Tisch FRM-CAL low volume calibrator.
2. Allow the calibrated barometric pressure device to reach equilibrium with the ambient air.
3. The barometric calibration can be performed by following these keystrokes:



4. Press the box and enter the pressure reading from the calibrator.
5. Press UPDATE to update the barometric pressure.

Barometric Pressure Sensor Calibration Screen

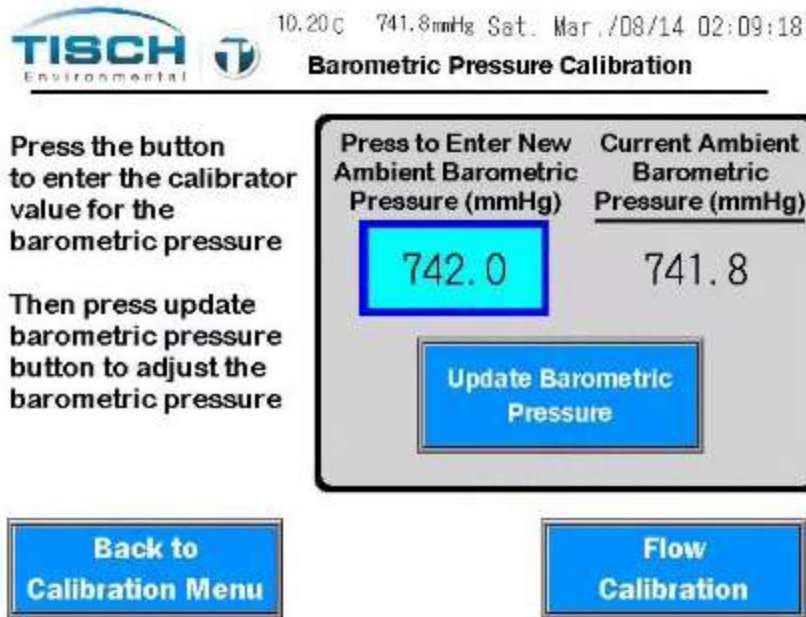

### 7.4 Volumetric Flow Calculation

The TE-Wilbur uses a highly accurate mass flow sensor to measure the mass flow of the flow system. The system then calculates the actual volumetric flowrate using the following formula:

$$Q_a = Q_s \times \left(\frac{P_s}{P_a}\right) \times \left(\frac{T_a}{T_s}\right)$$

Where:

$Q_a$  = Actual Flow or Volumetric Flow in Lpm

$Q_s$  = Mass flow

$P_s$  = Standard USEPA Barometric Pressure = 760 mmHg

$P_a$  = Actual Barometric Pressure Conditions in mmHg

$T_s$  = Standard USEPA ambient Temperature = 298.15 Deg K

$T_a$  = Actual ambient Temperature Conditions in Deg K

Rewriting:

$$Q_a = Q_s \times \left(\frac{760}{P_a}\right) \times \left(\frac{T_a + 273.15}{298.15}\right)$$

Where:  $T_a$  is now ambient temperature in Degrees Celsius.

Rewriting:

$$Q_a = Q_s \times 2.549 \times \left( \frac{T_a + 273.15}{P_a} \right)$$

Where:  $Q_a$  is the flow in Lpm,  $T_a$  is ambient temperature in Degrees Celsius and  $P_a$  is ambient barometric pressure in millimeters of mercury.

## 7.5 Flow Calibration

Flow calibration is performed using a four-point linear regression formula. Four points of flow are generated at 90% / 95% / 100% / 105% of setpoint. When flow calibration is started, the system automatically will start the flow system and will achieve each setpoint, allowing the user to enter the calibrator's flow reading at each step.

To calibrate the flow system, perform the following:

1. Flow calibration can be performed by following these keystrokes:



2. Place a known, calibrated flow standard onto the downtube of the TE-Wilbur unit such as the Tisch FRM-CAL low volume calibrator. This calibrator should be within its certification period.



Picture showing the TE-FRM-CAL calibration head inserted onto downtube



3. Place a filter cassette with a screen and filter into the filter holder and close the filter holder. NOTE: this filter cannot be used for subsequent sampling per USEPA Quality Assurance Guidance Document 2.12.
4. Proceed to the setpoint screen where the user can change the setpoint of the flow calibration. 16.67 Lpm is the default setpoint and should only be changed under abnormal operations.

Flow Calibration Setpoint Screen

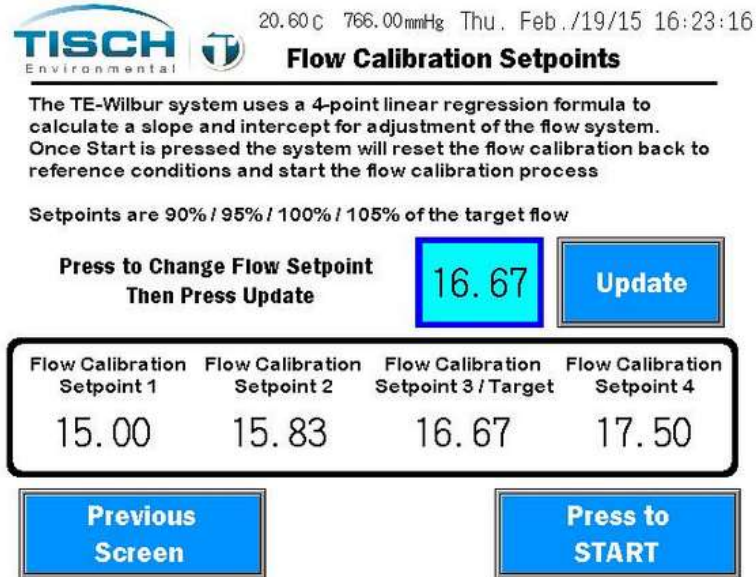

20.60 C 766.00mmHg Thu. Feb./19/15 16:23:16

**TISCH Environmental** **Flow Calibration Setpoints**

The TE-Wilbur system uses a 4-point linear regression formula to calculate a slope and intercept for adjustment of the flow system. Once Start is pressed the system will reset the flow calibration back to reference conditions and start the flow calibration process

Setpoints are 90% / 95% / 100% / 105% of the target flow

Press to Change Flow Setpoint  
Then Press Update

16.67 Update

Flow Calibration Setpoint 1	Flow Calibration Setpoint 2	Flow Calibration Setpoint 3 / Target	Flow Calibration Setpoint 4
15.00	15.83	16.67	17.50

Previous Screen Press to START

5. Press START and the Calibration Point 1 screen will be displayed and the flow system will start and will achieve the first setpoint. The setpoint and flow is shown on the left.



Flow Calibration Enter Reading Point 1 Screen



Thu. Feb./19/15 16:26:49

Flow Calibration Point 1

When flow stabilizes, enter the known calibrator flow,  
Then press accept to finish

<p>Press to Enter Calibrator Reading 1</p> <p>0.00</p> <p>Accept Point 1 Goto Point 2</p>	<p>Vol Air Flow (LPM)</p> <p>15.00</p> <p>Flow Setpoint 1 (LPM)</p> <p>15.00</p>
---	--

Quit  
Return to Main Menu

6. After the flow stabilizes, take a reading from the calibrator and press the blue box to enter the calibrator's reading.
7. Press the green ACCEPT box to accept that reading and continue to setpoint number two.
8. Perform setpoints two, three and four. After the fourth setpoint the final flow calibration screen will appear.

**NOTE:** If the **QUIT RETURN TO MAIN MENU** Button is pressed on any of the screens, the last successful calibration slope and intercept will be loaded into the flow calibration settings and the calibration will be terminated.

Flow Calibration Summary Screen

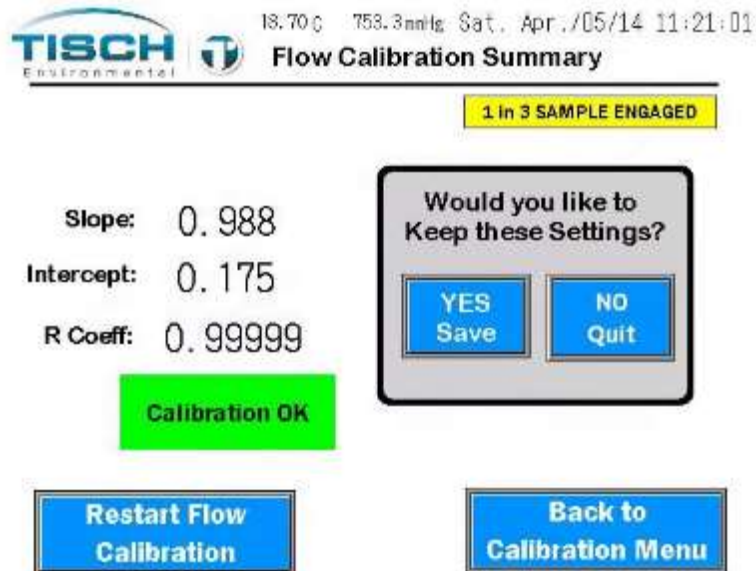

9. The user is presented with the slope, intercept and R coefficient of the four point linear regression formula. If the R coefficient is less than 0.98 the user is notified that the calibration needs attention.
10. If the R coefficient is greater than 0.98 and the user feels that the calibration was successful they can save the calibration values by pressing the YES SAVE button. If the user does not want to save the calibration settings they can press NO QUIT and the last calibration values will be used for flow adjustment.

## 7.6 Flow Calibration Equations

Linear Regression is a mathematical way to find the relationship between several variables. In the case of flow calibration, you are trying to find the relationship between what the calibrator is reading and what the flow sensor is reading you are trying to calibrate.

A straight regression line depicts a linear trend or relationship of the data. So the linear straight line equation of  $y = mx + b$  holds true. This means that you can calculate any point along the line given the reading of your sensor after this formula has been created. Where  $m$  = the slope of the linear line and  $b$  = the intercept of the line. The flow sensor is a linear relationship.

To calculate the slope of the line the following formula is used:

$$Slope = \frac{\sum xy - \frac{(\sum x)(\sum y)}{n}}{\sum x^2 - \frac{(\sum x)^2}{n}}$$

Where n = the number of data points  
 y = flow calibrator values  
 x = sampler flow values

To calculate the intercept of the line the following formula is used:

$$Intercept = \frac{\sum y}{n} - m \frac{\sum x}{n}$$

Where m = the slope calculated above

The flow can then be adjusted using the following formula:

$$Q_{adjusted} = Q_{actual} \times Slope + Intercept$$

Correlation Coefficient (r) - the closer this value is to 1.0 the better fit of the regression line. Simply put, the closer the line passes through all the points and the more accurate it is. A value of 1.0 is a perfect Correlation Coefficient any value less than 0.98 fails a calibration.

The Correlation Coefficient (r) is calculated by the following formula:

$$r = \frac{n \sum xy - (\sum x)(\sum y)}{\sqrt{n(\sum x^2) - (\sum x)^2} \sqrt{n(\sum y^2) - (\sum y)^2}}$$

## 7.7 Flow Calibration Audit / Verification

The flow system can be verified for audit purposes by these keystrokes:

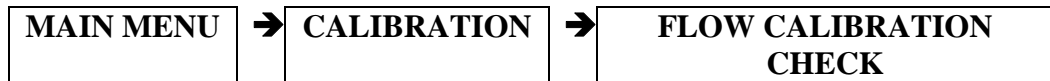

To verify the flow calibration

1. Each flow setpoint has a corresponding START button below it. Press each start button to have the flow system reach that flow setpoint.
2. Let the flow stabilize at that setpoint and compare the reading with a calibrated flow device such as a Tisch FRM-CAL low volume calibrator.
3. Press the STOP button or press the Calibration Main Menu return button to stop the flow verification.

Flow Calibration Check Screen

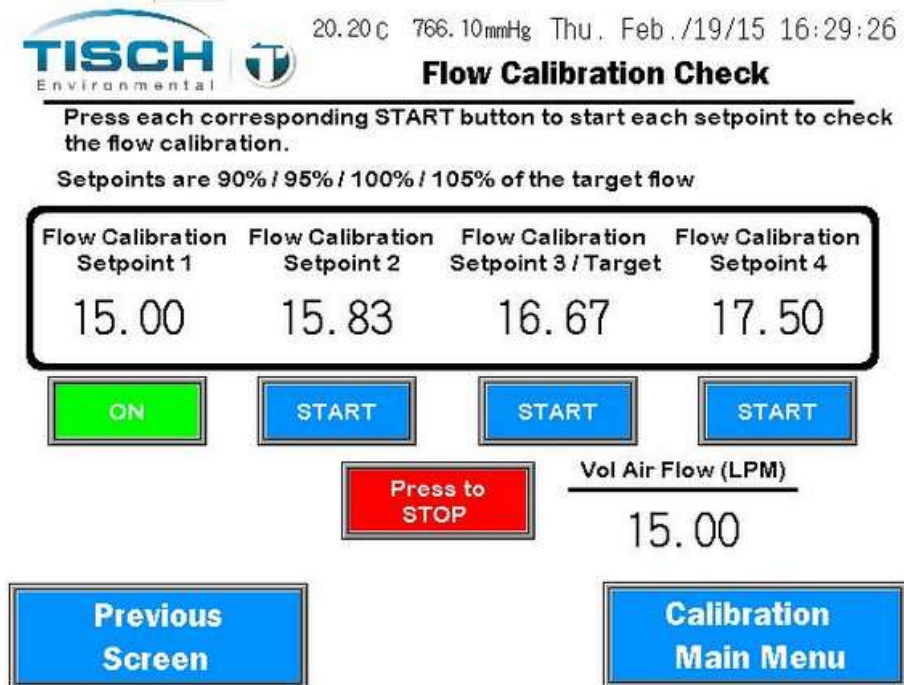

20.20 c 766.10mmHg Thu. Feb./19/15 16:29:26

**Flow Calibration Check**

Press each corresponding START button to start each setpoint to check the flow calibration.

Setpoints are 90% / 95% / 100% / 105% of the target flow

Flow Calibration Setpoint 1	Flow Calibration Setpoint 2	Flow Calibration Setpoint 3 / Target	Flow Calibration Setpoint 4
15.00	15.83	16.67	17.50

ON      START      START      START

Press to STOP

Vol Air Flow (LPM)

15.00

Previous Screen      Calibration Main Menu

**NOTE:** Calibration should be checked and verified at a minimum every 4 weeks. If the flow system is off by more than  $\pm 4\%$ , a full calibration should be performed.

## 7.8 Pressure Sensor Zero Trim

The pressure sensor is zeroed from the factory. If it does require a re-zero, follow these keystrokes:



When zeroing the pressure sensor, make sure there is no pressure on the system. Ensure the pump is not running and the system is vented to atmosphere.

First, press the **RESET PRESSURE SENSOR OFFSET** Button. This will set the offset to zero.

Once the pressure stabilizes, press the ‘Pressure Sensor Zero’ button to set the system pressure at zero.

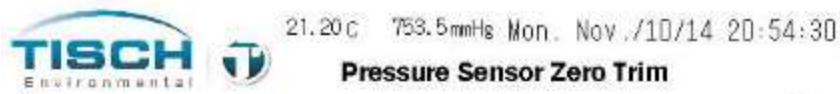

**To Zero the pressure sensor, power up the unit and wait for the pressure sensor to stabilize. Once stable press the Pressure Sensor Zero button to zero the pressure sensor**

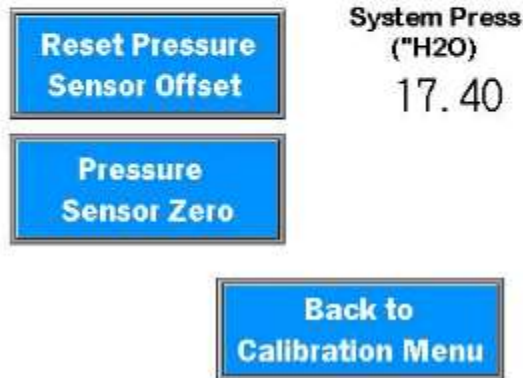

Reset Pressure Sensor Offset

Pressure Sensor Zero

Back to Calibration Menu

System Press ("H2O)  
17.40

## 7.9 TE-Wilbur Calibration Worksheet Instructions

1. Fill out the following information in the first box:

<b>Date / Time</b>	Current date and time
<b>Serial Number</b>	Serial Number of the TE-Wilbur unit
<b>Technician</b>	Technician performing the calibration
<b>Calibrator Make/Model</b>	The make and model of the calibrator you are using to perform the calibration
<b>S/N:</b>	The serial number of the calibrator you are using to perform the calibration
<b>Calibrator Due Date</b>	The date the calibrator is due for re-certification, this is typically 1-year after the last certification

2. The second box is the ambient temperature, filter temperature and barometric pressure calibration. Start an ambient temperature calibration. Refer to Section 7.1 of the Operations Manual for performing ambient temperature calibration. Enter the following information:

<b>As Found</b>	The current reading of ambient temperature of the TE-Wilbur system
<b>Calibrator Reading</b>	The current reading of the calibrator ambient temperature
<b>As Left</b>	The value of ambient temperature the TE-Wilbur system was left at. This should always be the calibrator reading

3. Perform a filter temperature calibration. Start a filter temperature calibration. Refer to Section 7.2 of the Operations Manual for performing an filter temperature calibration. Enter the following information:

<b>As Found</b>	The current reading of filter temperature of the TE-Wilbur system
<b>Calibrator Reading</b>	The current reading of the calibrator filter temperature
<b>As Left</b>	The value of filter temperature the TE-Wilbur system was left at. This should always be the calibrator reading

4. Perform a barometric pressure calibration. Start a barometric pressure calibration. Refer to Section 7.3 of the Operations Manual for performing a barometric pressure calibration. Enter the following information:

<b>As Found</b>	The current reading of barometric pressure of the TE-Wilbur system
<b>Calibrator Reading</b>	The current reading of the calibrator barometric pressure
<b>As Left</b>	The value of barometric pressure the TE-Wilbur system was left at. This should always be the calibrator reading

5. The second box is the flow calibration. Start a flow calibration. Refer to section 7.5 of the Operations Manual for performing a flow calibration.

At each setpoint screen (Setpoints will be 15.00/15.83/16.67/17.50 LPM when running at 16.67 LPM setpoint) record the following values in the Flow Calibration section of the worksheet. Repeat this 4 times for each setpoint

<b>As Found</b>	This is the current reading of the TE-Wilbur flow
<b>Calibrator Reading</b>	This is the current reading of the calibrator
<b>As left</b>	The value of flow the TE-Wilbur system was left at. This should always be the calibrator reading

After all 4 setpoints are entered and the calibration is successful, write down the Slope, Intercept and  $R^2$  factor in the spaces provided. Perform a flow verification by running the sampler at 16.67 Lpm. Write down the setpoint and the as found value, these should be the same.

6. The last box is the leak check results. Start a leak check. Refer to Section 11.0 of the Operations Manual for instructions on performing a leak check.

Record the start pressure after the system stabilizes, the fail pressure displayed on the screen and the final ending pressure after the leak check completes. Check the pass or fail box depending if the leak check has passed or failed.

7. Sign and date the calibration worksheet.



## TE-Wilbur Calibration Worksheet

145 South Miami Ave. Cleves, OH 45002 513.467.9000 sales@tisch-env.com

Date / Time: _____	Serial Number: _____	Technician: _____
Calibrator Make/Model: _____	Due Date: _____	S/N: _____

AMBIENT TEMPERATURE (°C)		
As Found	Calibrator Reading	As Left
_____	_____	_____
_____	_____	_____
FILTER TEMPERATURE (°C)		
As Found	Calibrator Reading	As Left
_____	_____	_____
_____	_____	_____
BAROMETRIC PRESSURE (mmHg)		
As Found	Calibrator Reading	As Left
_____	_____	_____
_____	_____	_____

FLOW CALIBRATION (Liters Per Minute)				
		As Found	Calibrator Reading	As Left
Slope: _____	1	_____	_____	_____
Intercept: _____	2	_____	_____	_____
R factor: _____	3	_____	_____	_____
	4	_____	_____	_____
		Setpoint	As Found	
Calibration Verification: _____		_____	_____	

LEAK CHECK RESULTS	
Leak Check Start Pressure: _____	(inches of H <sub>2</sub> O)
Leak Check Fail Pressure: _____	(inches of H <sub>2</sub> O)
Leak Check End Pressure: _____	(inches of H <sub>2</sub> O)
Leak Check Pass / Fail	Pass <input type="checkbox"/> Fail <input type="checkbox"/>

Technician: \_\_\_\_\_ Date: \_\_\_\_\_



## 8.0 Screen Maintenance

The Maintenance Menu allows you to setup the date and time, download data, adjust screen brightness, provide system information, disconnect the battery, control the system manually and several other functions.

### 8.1 Changing Date and Time

The time format for Wilbur is in 24-hour format, HH:MM:SS. The date format is in the format of MM/DD/YY. To change the date and time follow these instructions.

#### Changing the time

The Set Time and Date screen can be found by following these keystrokes:



The set time screen will appear first. To change the time, enter the Hours, Minutes and Seconds and press update. The time will be updated.

Change Time Screen



### Changing the date

To change the date, press the CHANGE DATE button which is located on the Update Time Screen.

Press each Month, Day and Year box and press update to update the date. You can return to the Maintenance Menu by pressing the Back to Maintenance Menu button.

Change Date Screen



## 8.2 Change Screen Brightness

To change the screen brightness, under the maintenance menu press the Adjust Screen Brightness button and the following popup screen will be shown. Press the Increase button to increase the brightness and the Decrease button to decrease the brightness.

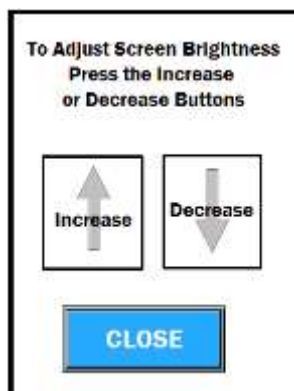

**NOTE:** After 5 minutes the brightness of the screen is halved and the screen is shutdown after 15 minutes to conserve power.

### 8.3 Battery Disconnect

In order to power down the sampler the battery must be disconnected before power is removed. To disconnect the battery, press the button that is labeled: **PRESS FOR BATTERY DISCONNECT**.

**NOTE:** If mains power is removed and the sampler is running on battery, pressing this button will power down the sampler. Mains power must be applied to the sampler to power on again.

### 8.4 Manual Control

In the manual control screen the system can be operated in automatic flow control mode by entering a flow setpoint or can be operated by adjusting the percent of speed of the pump with no flow control.

The manual control screen is found here:



To run the pump with automatic flow control, perform the following:

1. Enter the setpoint by pressing the setpoint box and entering in the flow setpoint for automatic flow control.
2. Press the START button underneath the flow setpoint.
3. The system will turn on and the pump will operate at the desired setpoint.
4. To stop the system press the STOP button below the setpoint box.

Manual Control Screen showing pump in flow control mode

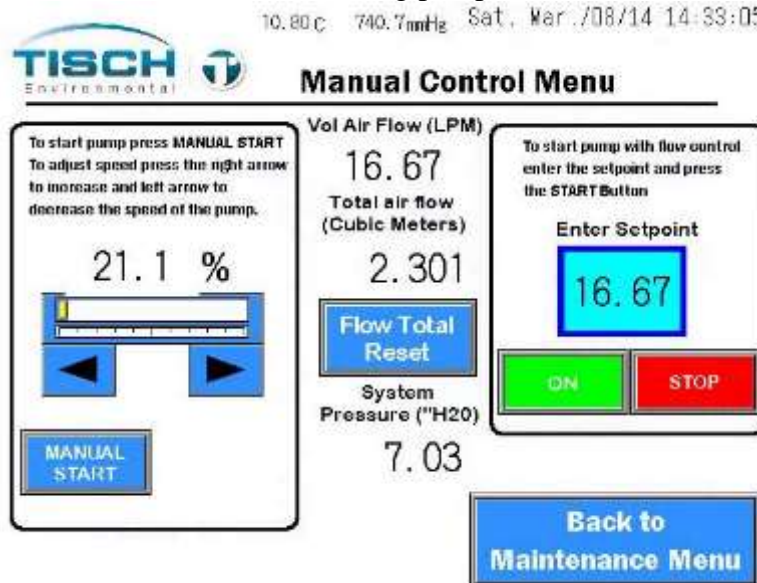

To operate the pump manually with a percent of speed, perform the following:

1. Press the MANUAL START BUTTON.
2. Press the ► right arrow button to increase the speed of the pump.
3. Press the ◀ left arrow button to decrease the speed of the pump.
4. Press the MANUAL STOP button to stop the pump.

Manual control screen showing pump in manual % speed control

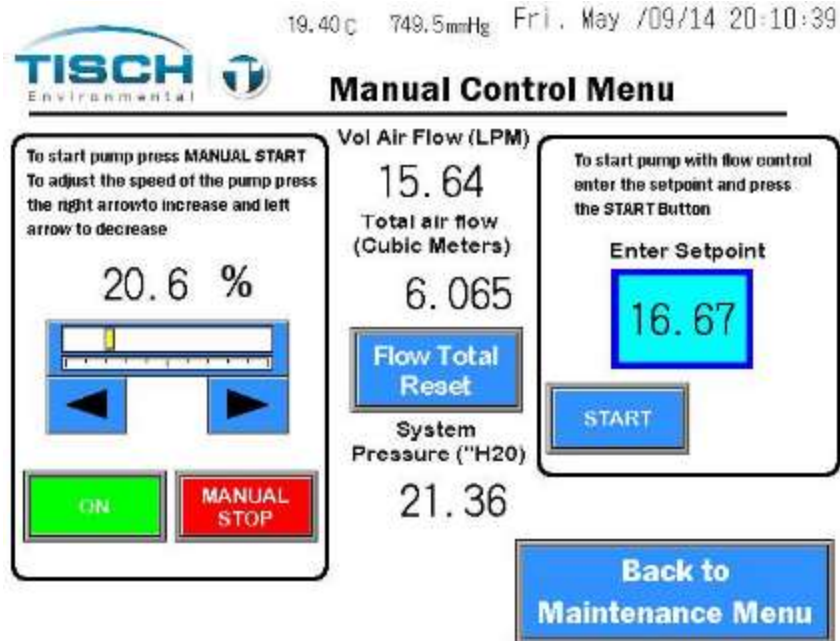

**NOTE:** If the system is running in manual mode and a sample starts, manual mode will be shut down and the sample will start as scheduled.

**NOTE:** When running in percent of pump speed manual mode, the only alarm that will shut down the pump is the high pressure alarm which is set to 200” H<sub>2</sub>O of pressure.

**NOTE:** When running in flow control manual mode, all the alarms that will shut down a sample will also shut down the automatic flow control in manual mode with the exception of the flow variance alarm and the ten consecutive power fails alarm. See section 1.4 – Sample Alarms for details.

## 8.5 System Information

The system information screen is where the software versions can be found along with the total sampling runtime and the pump runtime. The pump runtime can be reset here.

The system information screen can be found by following these keystrokes:



### System Information Screen



The screenshot shows the following information:

- Top left: **SAMPLE RUNNING** (green bar)
- Top right: Thu. Apr. /03/14 15:51:18
- Center: **TISCH Environmental** logo
- Center: **Tisch Environmental Wilbur PM2.5 Air Sampling System**
- Center: **Copyright 2014 Tisch Environmental**
- Center: **All Rights Reserved**
- Table:
 

Total Sampling Runtime (hours)	Pump Runtime (hours)
61.28	61.38
- Right side: **Reset Pump Runtime** button
- Bottom left:
  - PLC Software Version: 2. 62
  - Screen Software Version: 1. 01
  - Unit Serial Number: 9875
- Bottom right: **Back to Maintenance Menu** button

**Total Sampling Runtime** This is the total in hours that a sample has been running. This value is not resettable.

**Pump Runtime** This is the amount of time the pump has been running either sampling, in manual mode or performing calibrations. The pump runtime can be reset by pressing the Reset Pump Runtime button. Pump rebuilds are recommended at 3,000 hours and the operator is prompted when the pump has 3,000 hours of runtime. See section 12.0 – Maintenance for information on rebuilding the pump.

<b>PLC Software Version</b>	This is the software version that is currently loaded in the PLC controller.
<b>Screen Software Version</b>	This is the software version that is currently loaded into the screen.
<b>Unit Serial Number</b>	This is the serial number of the unit. The last 3 digits of the unit serial number is appended to the datalog and history log file names.

## 8.6 Data Download Menu

The data download menu can be found by following these keystrokes:



In the data download menu, several functions regarding the data log and USB functions can be accomplished such as:

<b>Download Run Summary Data</b>	Allows the operator to download the datalog that contains all of the pertinent run summary data. See Section 8.0 – Data Logging and Operational Data.
<b>Download History Data</b>	Allows the operator to download the history log that contains all the events and alarms that occurred.
<b>Eject USB</b>	Ejects the USB stick from the unit.  <b>NOTE:</b> If the USB stick is not ejected properly a warning will appear that will need acknowledged by pressing the ACK button in the center (See note below).
<b>Erase Data and Alarm Log</b>	Allows the user to erase the data log and alarm log. <b>This is a permanent erase that is non-recoverable from the internal memory.</b> This does not erase any data from the USB stick, but will clear the internal data and history log to start new logs.

**NOTE:** The datalog and history log filenames are appended with the last 3 digits of the unit's serial number.



**NOTE:** Before removing the USB drive from the USB port, the USB must be ejected by pressing the Press to Eject USB Drive button. This is to prevent data loss by stopping the USB access before the drive is removed. If the USB is removed without ejecting, a small screen will alert the user that next time they need to eject the USB before removing it.



Press the Ack button to acknowledge this warning.

### Data Download Menu

-123.45 c -123.4 mmHg Sat. Mar./01/14 09:12:11



### Data Management Menu

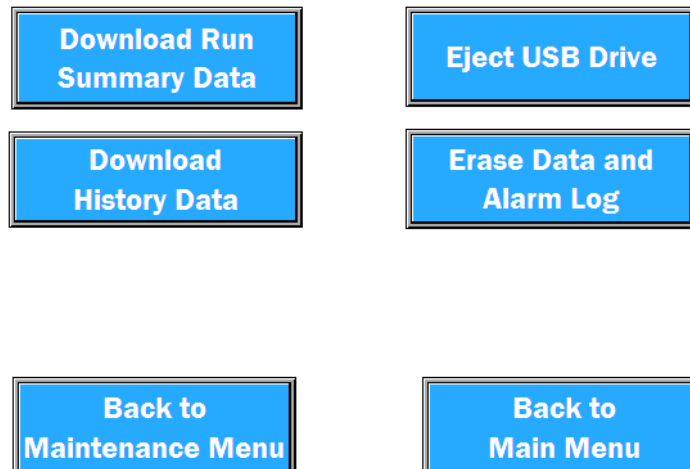

## 8.7 Update Firmware

To update the firmware of the screen or the controller perform the following:

1. The firmware files must be first downloaded from the Tisch Environmental website at [www.tisch-env.com](http://www.tisch-env.com).
2. Ensure you are downloading the latest firmware revision and read the firmware revision notes.

The filename for the screen is: wilburscreen.znv

The filename for the controller is: wilburplc.zld

3. Place these files on the root directory of a USB stick and insert the USB stick into the USB socket.
4. When the pop-up for inserting a USB appears press CLOSE WINDOW to close the pop-up.
5. The update firmware can be found by following these keystrokes:



6. When the Update Firmware from USB is pressed the following pop-up window will appear alerting the operator that there could be a critical failure if this is not done properly:

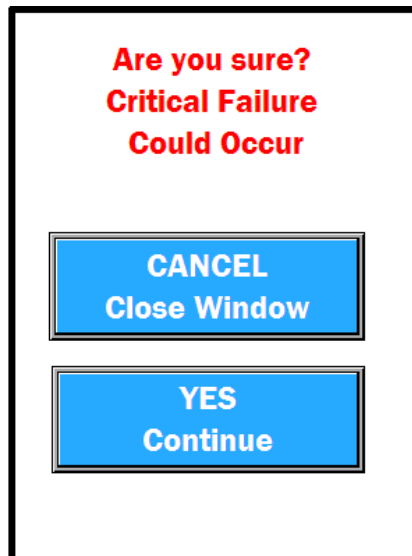

7. Ensure the system is plugged into a reliable power source before performing the firmware updates. Loss of power during a firmware update could corrupt the system causing a failure.
8. Press the YES Continue button and the operator will be prompted for which firmware update they would like to perform – screen update or controller update.



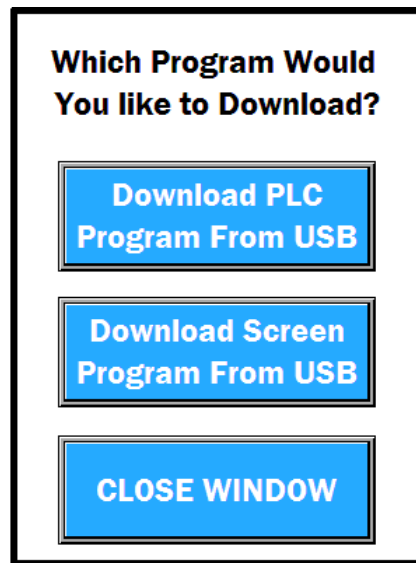

9. To update the controller firmware, press the Download PLC Program from USB. PLC stands for 'Programmable Logic Controller' which is the controller platform used in the TE-Wilbur. It will take about a minute to update the firmware and when complete the operator will be prompted that the update was successful or if the update failed and to press acknowledge.
10. To update the screen firmware, press the Download Screen Program from USB. It will take about a minute to update the firmware and when complete the operator will be prompted that the update was successful or if the update failed and to press acknowledge.
11. Press the CLOSE WINDOW button to close the firmware update popup and press the EJECT USB button to eject the USB drive. Remove the USB drive.

**NOTE:** If the Firmware update fails, ensure the file is on the root of the USB drive. Also ensure the files have the correct file names. Try using a different USB drive to perform the update and if you are still having troubles call Tisch Environmental at 1-877-263-7610 (1-877-TSP-AND-PM10).

## 8.8 Change Sample Setpoint

The sample setpoint can be changed by following these keystrokes:



To change the setpoint press the setpoint box, type in the value of the setpoint and press the ENT key to accept.

**NOTE:** Changing the setpoint will cause the sampler when sampling to run at this setpoint. Per USEPA specifications the setpoint should always be set to 16.67 Lpm for proper operation.

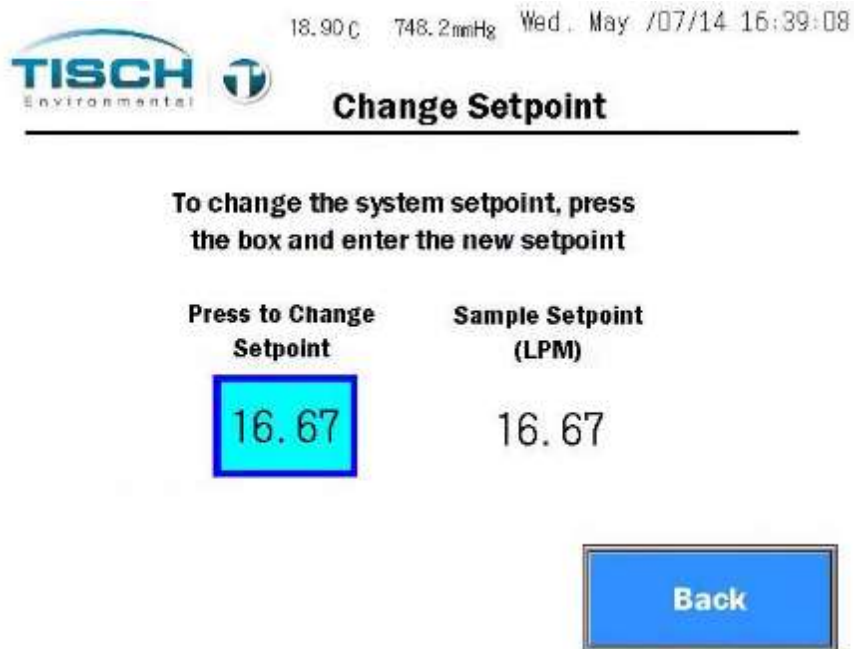

## 8.9 Change MODBUS Address

The address of the MODBUS communication port can be changed by pressing the Change Modbus Address button found by following these keystrokes:



Change Modbus Address Pop-up screen

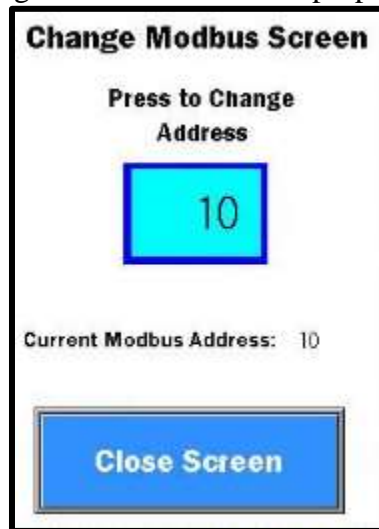

See Section 14 - Communications for more information on Modbus.

## 8.10 Datalogging Time

The time that the data log stores its values can be changed by pressing the Datalog Time Setting button found by following these keystrokes:



**NOTE:** Per USEPA this value is defaulted to 300 seconds (5 minutes). Any deviation of this may invalidate sample data.

Change Datalog Timing pop-up screen



## 9.0 Data Logging / Operational Data

This section explains the data functions with TE-Wilbur, how data is collected, stored in the datalog and displayed on the screen.

### 9.1 Operational Data

The operational data can be found by following these keystrokes:

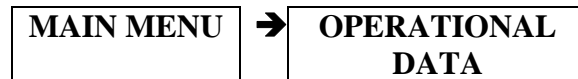

There are (3) screens of operational data. On these screens the following information is presented to the operator:

**Volumetric Air Flow (Lpm)**

The volumetric air flow ( $Q_{\text{actual}}$ ) of the system in real time and the maximum and minimum volumetric flow rate updated every 30 seconds.

**Barometric Pressure (mmHg)**

The barometric pressure in millimeters of mercury in real time and the maximum and minimum barometric pressure updated every 30 seconds.

**System Pressure ("H<sub>2</sub>O)**

The system vacuum pressure in inches of water in real time and the maximum and minimum system pressure updated every 30 seconds.

**Filter Temp (Deg C)**

The filter temperature in degrees Celsius in real time and the maximum and minimum filter temperature updated every 30 seconds.

**Ambient Temp (Deg C)**

The ambient temperature in degrees Celsius in real time and the maximum and minimum ambient temperature updated every 30 seconds.

**Temperature Variance (Deg C)**

The difference between the ambient temperature and the filter temperature in real time and the maximum and minimum temperature variance updated every 30 seconds.

**Total Airflow (Liters / m<sup>3</sup>)**

The total air flow shown in cubic meters and in liters.

- Sample runtime (Hours)** The sample runtime that is currently running or the last sample runtime that has just completed.
- Average flowrate of the sample (Lpm)** The average flowrate of the sample that is currently running or the average flowrate of the sample that has just completed.
- Filter and Site ID** The filter and site ID entered by the operator.

## 9.2 Downloading Data to USB

Data from the data log and the history log are saved from the internal memory of the screen onto an SD card located in the screen. The data that is saved to the SD card can then be downloaded to a USB by inserting a USB drive into the USB port on the front of the unit or by accessing the Data Download screen at the following location:



When inserting a USB drive into the USB port on the front the following popup screen will appear:

USB Inserted popup Screen

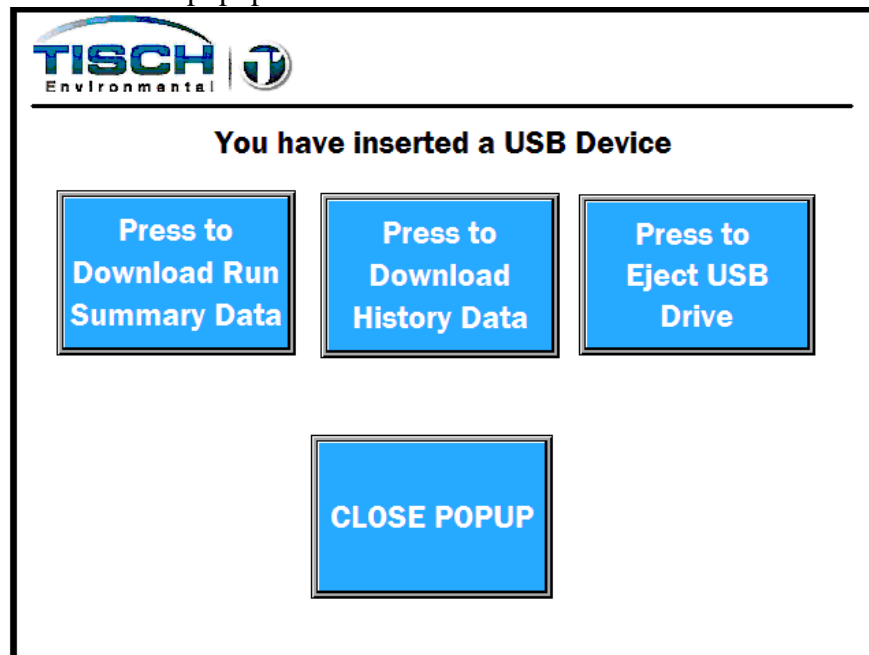

On this popup screen the operator can download the run summary data which is the operational log described in 9.3 of this section and the history log which is described in Section 10.0 of this manual.

**NOTE:** Before removing the USB drive from the USB port, the USB must be ejected by pressing the Press to Eject USB Drive button. This is to prevent data loss by stopping the USB access before the drive is removed. If the USB is removed without ejecting, a small screen will alert the user that next time they need to eject the USB before removing it.



Press the Ack button to acknowledge this warning.

### 9.3 Datalog

The datalog stores all data values based on the datalog timer setting which can be changed here:



The default time for the data log is 5 minutes (300 seconds).

The datalog will continuously log data regardless if a sample is running.

The datalog is in a standard comma separated value (.CSV) file which can be opened from any standard spreadsheet program. The datalog is stored as the filename wilbur\_data.csv with the three digit number of the sampler's serial number appended to the file name. So if the sampler's serial number is 4786 the filename will be: wilbur\_data786.CSV.

When downloading to a USB drive, a folder called run\_summary\_data is created and the datalog will be stored in that location.

The datalog contains the following information:

- Qvol avg** The average volumetric air flow (Qactual) over the time of the datalog timer in liters per minute.
- Qvol max** The maximum value of volumetric air flow (Qactual) over the time of the datalog timer in liters per minute.
- Qvol min** The minimum value of volumetric air flow (Qactual) over the time of the datalog timer in liters per minute.

- Pa avg** The average barometric pressure in mmHg over the time of the datalog timer.
- Pa max** The maximum barometric pressure in mmHg over the time of the datalog timer.
- Pa min** The minimum barometric pressure in mmHg over the time of the datalog timer.
- Tfilter avg** The average temperature in degrees Celsius of the filter temperature over the time of the datalog timer.
- Tfilter max** The maximum temperature in degrees Celsius of the filter temperature over the time of the datalog timer.
- Tfilter min** The minimum temperature in degrees Celsius of the filter temperature over the time of the datalog timer.
- Tamb avg** The average temperature in degrees Celsius of the ambient temperature over the time of the datalog timer.
- Tamb max** The maximum temperature in degrees Celsius of the ambient temperature over the time of the datalog timer.
- Tamb min** The minimum temperature in degrees Celsius of the ambient temperature over the time of the datalog timer.
- Press avg** The average suction pressure in inches of water of the system over the time of the datalog timer.
- Press max** The maximum suction pressure in inches of water of the system over the time of the datalog timer.
- Press min** The minimum suction pressure in inches of water of the system over the time of the datalog timer.
- TVar avg** The average temperature variance between the ambient temperature sensor and the filter temperature sensor in degrees Celsius over the time of the datalog timer.
- TVar max** The maximum temperature variance between the ambient temperature sensor and the filter temperature sensor in degrees Celsius over the time of the datalog timer.

**TVar min** The minimum temperature variance between the ambient temperature sensor and the filter temperature sensor in degrees Celsius over the time of the datalog timer.

**Flow total** The total flow in liters updated based on the time of the datalog timer. If the sample has stopped this will be the total flow of the last sample completed. The flow total is reset to zero when a new sample is started.

**Flow CV** The flow coefficient of variance from the start of the datalog timer to the end of the datalog timer.

**Filter ID** The filter ID entered by the operator.

**Site ID** The site ID entered by the operator.

**Unit S/N** The serial number of the sampler.

**NOTE:** The datalog will fill up after its size allocation is exceeded. When this happens the older data will get replaced by the newer data. If the data log is set to the 5 minute recommended setting, it will take several years to fill up the data log.

The larger the data and history logs are, the longer it will take to copy them to the USB stick. Resetting them periodically is recommended.

## 9.4 Erasing the Datalog

To erase the datalog go to the following screen:



The datalog and the alarm log will be erased. This function cannot be undone, so ensure the datalog and history log have been saved before continuing.



**NOTE:** This is a permanent erase that is non-recoverable from the internal memory. This does not erase any data from the USB stick, but will clear the internal data and history log to start new logs. Ensure the data is downloaded and verified prior to erasing the logs.



## 10.0 History Log

This section explains the history log, alarms and how data is stored and retrieved from the history log.

### 10.1 History Log Introduction

The history log can be found by following these keystrokes:

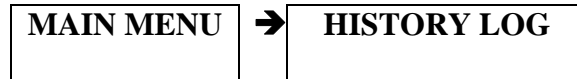

The history log contains all pertinent information that has occurred operationally with the sampler.

#### History Log Screen



19.40 C 753.3mmHg Sat. Apr./05/14 12:05:20

**TISCH Environmental** History Log

Time Occurred	Event Description	Time Cleared
04/05 11:37	Pump has been started in manual	04/05 12:04
04/05 11:27	Pump has been started in manual	04/05 11:29
04/05 11:20	Flow Calibration completed - passed	04/05 11:21
04/05 11:16	Flow Calibration started	04/05 11:20
04/05 10:23	1 in 3 sample selected	04/05 11:21
04/05 10:23	Sample has been engaged	04/05 11:21
04/04 11:39	Battery Failure - Replace Batteries	04/04 11:39
04/04 11:35	Power Failure	04/04 11:39
04/04 11:35	Mains Power Lost	04/04 11:35
04/04 11:35	Battery discharged	04/04 11:35
04/04 11:35	Mains Power Lost	04/04 11:35

DOWN UP Acknowledge Alarms Close Window

When an event or an alarm occurs it is logged on this screen and also saved to the SD card, which then can be downloaded to a USB drive by either inserting a USB drive into the USB port or proceeding to the data download menu at:



When an alarm occurs, it must first be resolved then it can be acknowledged by pressing the Acknowledge Alarms button.

So if for example, the ambient temperature sensor is unplugged, the history log screen will be shown notifying the operator that there is a problem. The ambient temperature sensor notification will be highlighted and will be red.

If the operator plugs the ambient temperature sensor back in, the alarm will still be highlighted and active until the operator acknowledges the alarm by pressing the acknowledge alarm button. Once that is pressed, the alarm will turn black indicating that it is no longer active and the system will be back to normal.

The alarm/event is time and date stamped when it occurred and when it was resolved.

The following two colors are used:

**RED** Indicates that an event or an alarm is active and is in progress. So for example when a sample is engaged this will be shown in red on the history log until that sample is canceled.

**BLACK** Indicates that an event or an alarm is no longer active or in progress. So when an alarm is cleared and then acknowledged it will be black.

**NOTE:** When there is an active alarm that requires attention, there will be this symbol shown on the top right corner of every screen:



The operator can go directly to the history log by pressing this symbol.

## 10.2 Alarms and Events

The following alarms and events are shown and logged in the history log:

Pump has been started from the screen	The pump has been started in either manual by pump speed percentage or by manual, automatic flow control.
Leak check started	Leak check was started.
Leak check passed	Leak check has passed and any leaks are less than 80mL/min.
Leak check failed	Leak check failed and there was a leak greater than 80mL/min.
Leak check failed – did not reach pressure	Indicates the Leak Check Failed due to the 60 second fail timer ending and the system pressure did not reach 50” H <sub>2</sub> O. Indicates the filter holder or valve adapter was not closed.
Flow calibration started	A flow calibration was started.
Flow calibration quit by operator	A flow calibration was started but was terminated by the operator.
Flow calibration completed – Passed	Flow calibration was completed and R factor was less than 0.98 and passed.
Flow calibration completed – Failed	Flow calibration was completed and R factor was greater than 0.98 and failed.
Flow Check Setpoint 1 Started	Operator performed a flow system verification for setpoint 1.
Flow Check Setpoint 2 Started	Operator performed a flow system verification for setpoint 2.
Flow Check Setpoint 3 Started	Operator performed a flow system verification for setpoint 3.
Flow Check Setpoint 4 Started	Operator performed a flow system verification for setpoint 4.
Sample has been engaged	1in3, 1in6, 1in12 or custom sample is engaged.
Sample has been started	1in3, 1in6, 1in12 or custom sample is started.
1 in 3 sample selected	1in3 sample has been selected and engaged.

1 in 6 sample selected	1 in 6 sample has been selected and engaged.
1 in 12 sample selected	1 in 12 sample has been selected and engaged.
Custom sample selected	A custom sample has been selected and engaged.
Flow variance alarm during sample	The flow varied by more than 10% for 10 minutes during a sample – this will shut down a sample.
5% Flow variance warning	The flow varied by more than 5% for 5 minutes, will give a warning for the sample.
Sample less than 23 or greater than 25 hours	The sample time was less than 23 hours or greater than 25 hours, most probably due to a complete loss of power. Will give a warning for a sample.
Ambient temperature unplugged or failed	The ambient temperature sensor was unplugged, dropped below -90 Deg C, went above +60 Deg C or there was an internal problem with the controller – this will shut down a sample.
Filter temperature unplugged or failed	The filter temperature sensor was unplugged, dropped below -90 Deg C, went above +60 Deg C or there was an internal problem with the controller – this will shut down a sample.
Flowmeter unplugged or failed	The flowmeter was unplugged, went above 25 Lpm, below 0 Lpm or there was an internal problem with the controller – this will shut down a sample.
Barometric press sensor unplugged or failed	The barometric pressure sensor was unplugged, went below 550 mmHg, went above 850 mmHg or there was an internal problem with the controller – this will shut down a sample.
System pressure sensor unplugged or failed	The pressure sensor went above 15 psi of vacuum, fell below 0 psi or there was an internal problem with the controller.
Sample shutdown due to alarm condition	The current sample was terminated due to an alarm.
5 Deg temp variance for 30 minutes	The difference between the ambient temperature and the filter temperature was greater than 5 Degrees Celsius
Barometric pressure updated	The barometric pressure sensor was calibrated and updated to a new value
Filter temperature updated	The filter temperature sensor was calibrated and updated to a new

	value.
Ambient temperature updated	The ambient temperature sensor was calibrated and updated to a new value.
Mains power lost	The system lost mains (AC) power and is now running on reserve DC power.
Power Fail	The system lost mains (AC) power and also reserve DC power and powered down completely.
Pump maintenance needed	The pump maintenance timer which is set to 5,000 hours has been exceeded. Indicating that pump maintenance is needed.
High system pressure shutdown	The system pressure reached 250 “H <sub>2</sub> O of vacuum pressure – this will shut down a sample.
Flow Check Setpoint 1-4 Started	The operator has started a flow verification and used setpoint 1 thru 4.
Screen battery needs replaced	The battery in the touchscreen needs replaced. This battery is crucial for proper system operation see 12.0 Maintenance for instructions on replacing the screen battery.
Battery Discharged	The internal batteries have reached a voltage level where they are fully depleted.
Battery failure – replace batteries	The internal batteries have failed and need replaced. See section 12.0 Maintenance for instruction on replacing the battery pack.

### 10.3 Alarm Flowchart

The following shows how an alarm occurs, is acknowledged and returns to normal operation with an example of the ambient temperature sensor being unplugged.

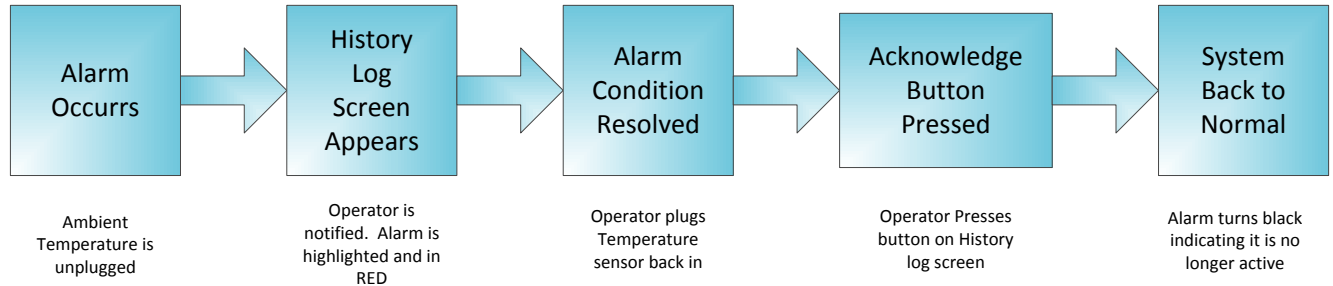

### 10.4 History Log Download

Data from the data log and the history log are saved from the internal memory of the screen onto an SD located in the screen. The data that is saved to the SD card can then be downloaded to the USB stick by inserting a USB stick into the USB port on the front of the unit or by accessing the Data Download screen by the following keystrokes:



When inserting a USB drive into the USB port on the front the following popup screen will appear:

USB Inserted popup Screen

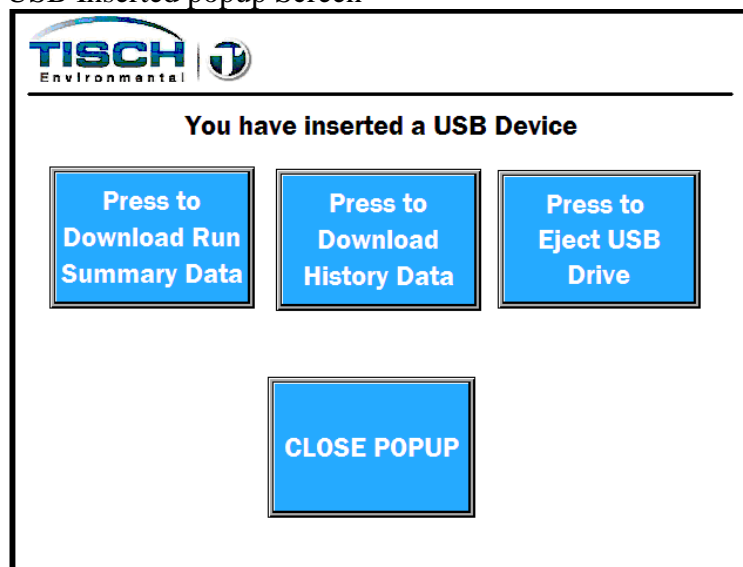

On this popup the operator can download the run summary data which is the datalog described in Section 8.0 of this section and the history log.

**NOTE:** Before removing the USB drive from the USB port, the USB must be ejected by pressing the Press to Eject USB Drive button. This is to prevent data loss by stopping the USB access before the drive is removed. If the USB is removed without ejecting, a small screen will alert the user that next time they need to eject the USB before removing it.



Press the Ack button to acknowledge this warning.

The history log is in a standard comma separated value (.CSV) file which can be opened from any spreadsheet program. The history log is stored as the filename wilbur\_history.csv with the last three digits of the units serial number appended to the file name. So if the serial number of the unit is 4786 the filename will be: wilbur\_history786.CSV.

When downloading to a USB drive, a folder called history log is created and the history log will be stored in that location.

### 10.5 Erasing the History Log

To erase the history follow these keystrokes:



The datalog and the alarm log will be erased. This function cannot be undone, so ensure the datalog and history log have been saved before continuing.



**NOTE:** This is a permanent erase that is non-recoverable from the internal memory. This does not erase any data from the USB stick, but will clear the internal data and history log to start new logs. Ensure the data is downloaded and verified prior to erasing the logs.

# 11.0 Leak Checks

This section details the leak check functions of TE-Wilbur.

## 11.1 Leak Check Introduction

There are two types of leak checks, an internal leak check and an external leak check. The external leak check checks the entire system from the output of the solenoid, to the end of the downtube and utilizes a TE-L30 adapter to plug the flow stream where the TE-PM10-D head would normally be. The internal leak check uses a TE-W-004 solid, blank disk that is inserted into the filter holder and checks the leak from the bottom of the filter holder to the output of the solenoid, bypassing any leaks in the filter holder, downtube or TE-L30 adapter. Per USEPA 40CFR Part50 App. L the sampler must be able to pass a leak check to demonstrate a leak of no more than 80mL/min is present. Using thermodynamic formulas the sampler calculates the ending pressure necessary to pass a leak check that demonstrates no more than an 80mL/min leak in the system.

**Pneumatic flow diagram of TE-Wilbur**

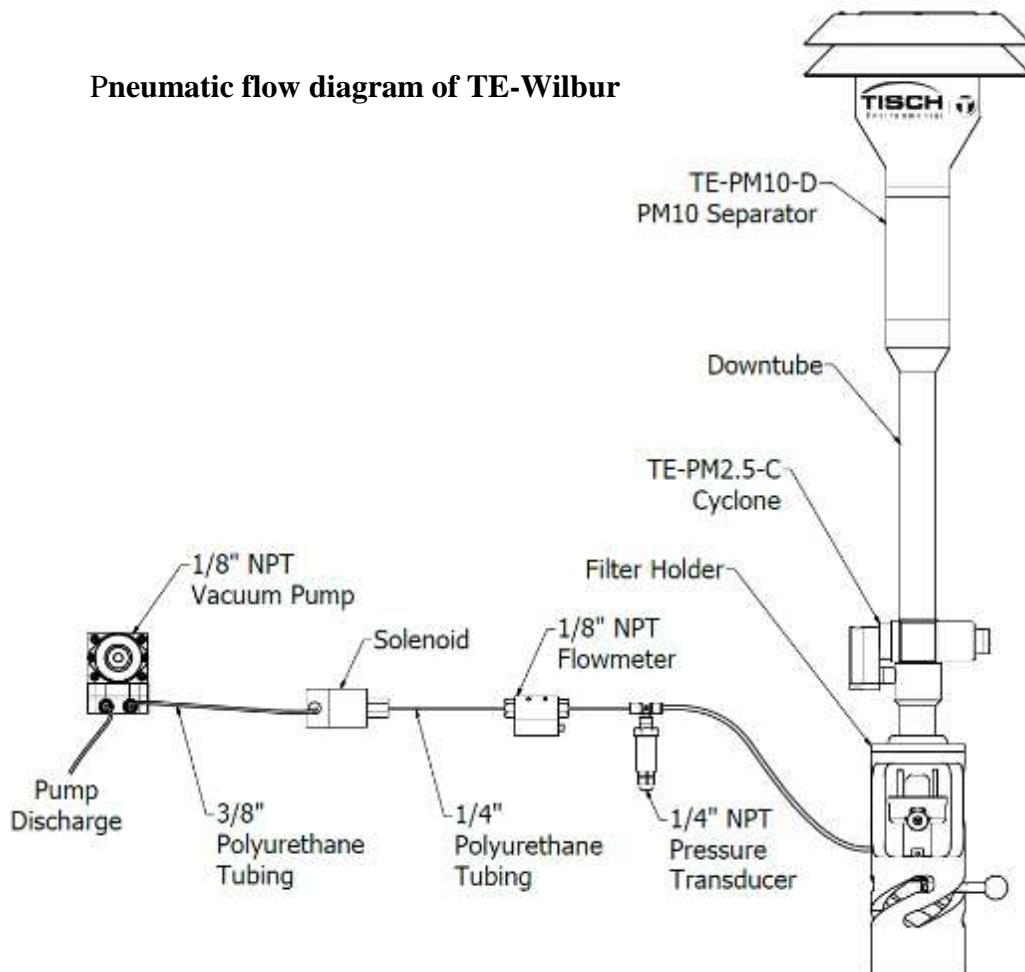



Leak checks can be performed by following these keystrokes:

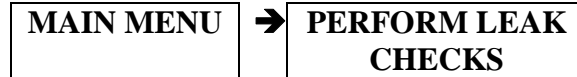

**NOTE:** If the pressure sensor is failed, leak checks will not be available and the following box will appear, disabling the leak check feature.

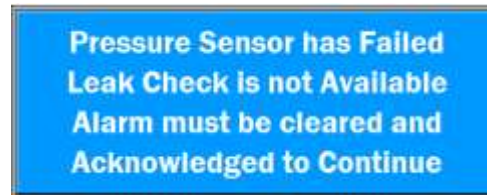

## 11.2 External Leak Check

To perform an external leak check, perform the following steps:

1. Insert a clean filter (designated the “leak check filter”) into a filter cassette with a screen and insert the cassette into the sampler filter holder.

**NOTE:** Leak check filters should never be used for subsequent sampling. The same filter may be used for the leak check that was used for the flow rate verification check.

2. Close the filter holder
3. Remove the PM-10 inlet and install the TE-L30 flow rate adapter on the top of the downtube.

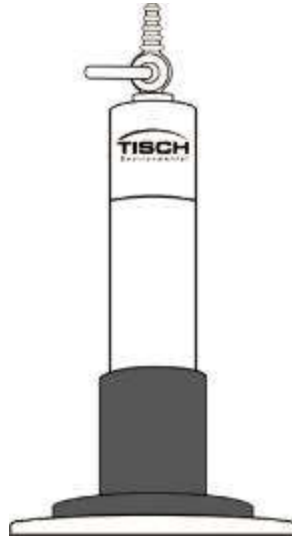

Picture of the TE-L30 Downtube adapter placed on top of the downtube with the valve in the closed position

4. Close the valve on the flow rate adapter to plug the air flow.
5. Press the Select External Leak Check button on the Leak check selection screen.
6. At the Perform External Leak Check Next Steps screen, the screen will show the TE-L30 adapter closed and the filter holder closed. Press next step and then press the Final Step button.
7. You will now be at the Leak Check Control Screen.

Leak Check Control screen

### Perform Leak Check Final Step

1. Press the START Button, Pump will start
2. After a 20 second delay, a 1-minute timer will start
3. When timer expires system will Indicate pass or fail

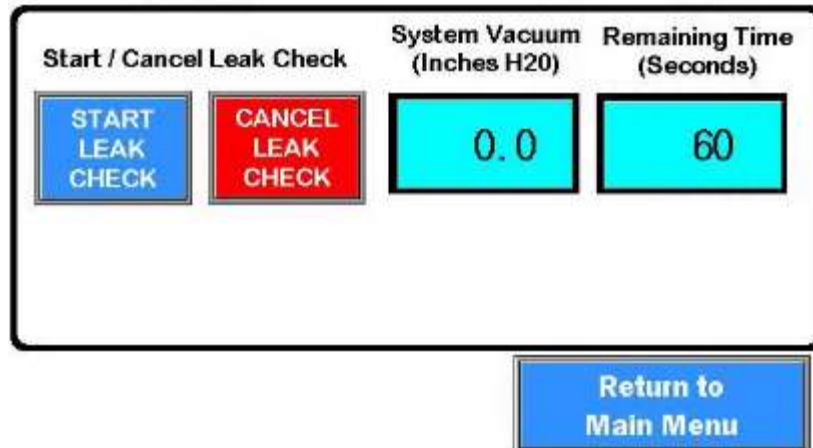

8. Press the START LEAK CHECK button.
9. The system will start the pump and pull a vacuum on the system.

**NOTE:** if the TE-L30 adapter is not closed and the vacuum does not reach 50" H<sub>2</sub>O, after 60 seconds the system will stop and fail.

10. Once the system pulls a vacuum of 50" H<sub>2</sub>O, the solenoid will close, isolating the system from the solenoid to the TE-L30 adapter. The final ending pressure will be much greater than 50" H<sub>2</sub>O since the system will stabilize to a final ending pressure.
11. After 20 seconds to allow the system to stabilize, the leak check timer of 60 seconds will start and the system will calculate the final ending pressure in order to pass an external leak check of less than 80mL/min.
12. If the external leak check passes, a green box will appear after the leak check timer expires indicating the external leak check has passed.
13. If the external leak check fails, meaning the vacuum pressure has dropped below the final ending pressure, meaning a leak of more than 80mL/min is present, a red box will appear after the leak check timer expires indicating the external leak check has failed.
14. To cancel the external leak check press the CANCEL LEAK CHECK button at any point or press the return to main menu button.
15. After the external leak check is completed, open the TE-L30 adapter slowly to prevent any damage from the inrush of air into the system.

### 11.3 Internal Leak Check

To perform an internal leak check, perform the following:

1. Place the solid internal leak check disk into the filter holder.

TE-W-004 Solid internal leak check disk

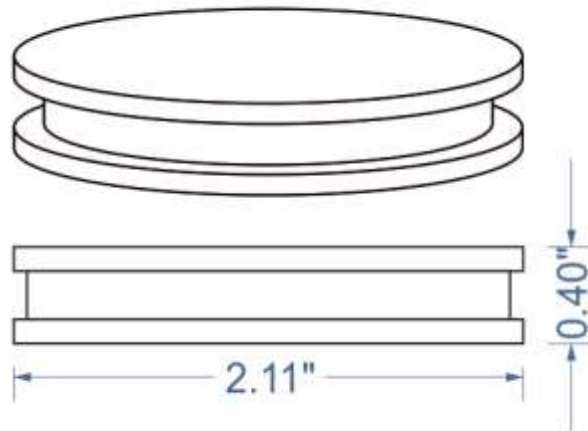

2. Close the filter holder.
3. Press the Perform Internal Leak Check at the leak check select screen.
4. At the step 1 screen press next step to go to the step 2 screen.
5. At the step 2 screen press final step to go to the leak check control screen.
6. You will now be at the Leak Check Control Screen.

Leak Check Control screen

### Perform Leak Check Final Step

1. Press the START Button, Pump will start
2. After a 20 second delay, a 1-minute timer will start
3. When timer expires system will Indicate pass or fail

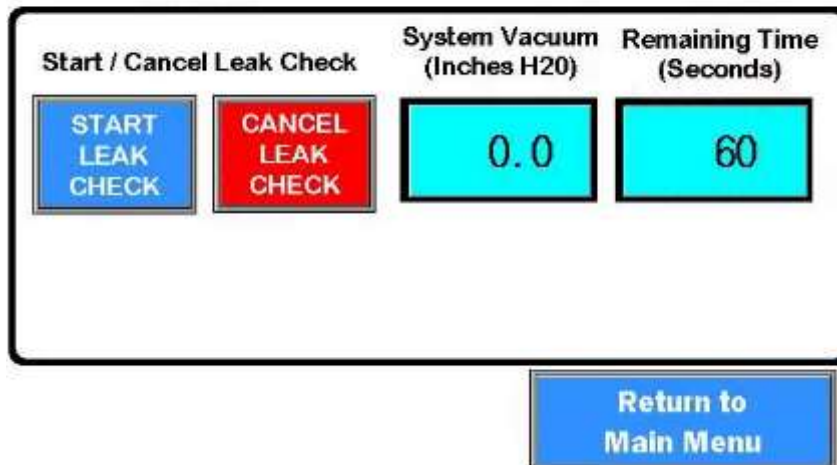

7. Press the START LEAK CHECK button.
8. The system will start the pump and pull a vacuum on the system.

**NOTE:** if the system vacuum does not reach 50" H<sub>2</sub>O, after 60 seconds the system will stop and fail.

9. Once the system pulls a vacuum of 50" H<sub>2</sub>O, the solenoid will close, isolating the system from the solenoid to the bottom half of the filter cassette. The final ending pressure will be greater than 50" H<sub>2</sub>O since the system will stabilize to a final ending pressure.
10. After 20 seconds to allow the system to stabilize, the leak check timer of 60 seconds will start and the system will calculate the final ending pressure in order to pass an internal leak check of less than 80mL/min.
11. If the internal leak check passes, a green box will appear after the leak check timer expires indicating the leak check has passed.
12. If the internal leak check fails, meaning the vacuum pressure has dropped below the final ending pressure, a red box will appear after the leak check timer expires indicating the internal leak check has failed.
13. To cancel the internal leak check press the CANCEL LEAK CHECK button at any point or press the return to main menu button.
14. After the internal leak check is completed, remove the internal leak check disk and return unit back to normal operation.

## 11.4 Leak Check Troubleshooting

If the external or internal leak check fails, consider the following troubleshooting techniques.

### External Leak Check

- Ensure there is a filter and screen in the filter cassette, the filter holder is closed and the filter cassette is seated properly in the filter holder.
- Ensure the TE-L30 adapter is on top of the downtube and the valve is closed.
- Check all the o-rings in the TE-L30, the downtube and the filter holder top and bottom halves for wear or damage. Replace worn or damaged o-rings.
- Ensure the o-rings are greased.
- Try a different filter cassette, TE-L30 adapter or downtube.
- If leak checking with a cyclone in place, ensure all o-rings in the cyclone are not damaged or worn. Ensure the connector is tight and the collector cup is tight.
- Perform an internal leak check. If the internal leak check passes, then the leak is somewhere from the filter holder up to the TE-L30 adapter
- Make adjustments to the filter holder to tighten it. See section 3.0 for instructions on the filter holder adjustment.
- If the external leak check fails see below for troubleshooting.

### Internal Leak Check

- Make sure the solid internal leak check disk is inserted and seated properly into the filter holder.
- Ensure the filter holder is closed and the filter cassette is seated properly in the filter holder.
- Try a different leak check disk.
- Check the thermo-well on the front of the filter holder to ensure it is tight and sealed.
- Check all internal fittings to ensure they are tight and sealed – see section 12.0 Maintenance for instructions on opening the front cover.
- Check the tightness of the filter holder mechanism and adjust to tighten. See Section 3.0 – Filter Handling / Filter Holder for instructions on tightening the filter holder mechanism.



**DISCONNECT MAINS POWER AND BATTERY POWER BEFORE OPENING THE FRONT COVER**

## 12.0 Solar / Alternative Energy

This section explains the optional solar panel accessory and the alternative energy connection for TE-Wilbur.

### 12.1 Introduction

The TE-Wilbur sampler has the ability to be run on alternative 24VDC power from solar, wind, external batteries or any other 24VDC source. An external DC connector is provided to allow connection to the alternative DC source.

### 12.2 Solar Wiring Overview

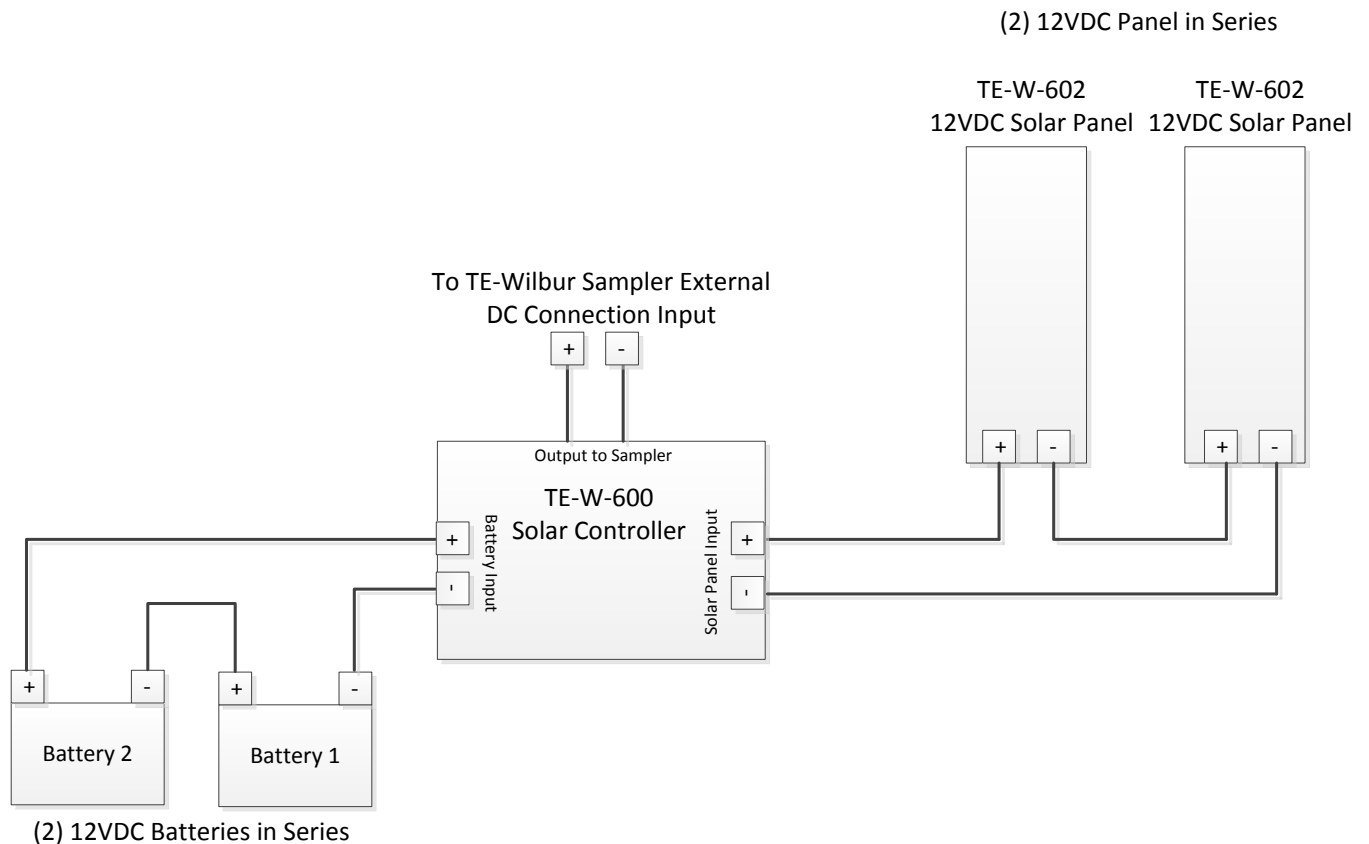



### 12.3 Solar Accessories

Accessory P/N	Description
TE-W-600	Complete solar kit with (2) 12V 100Watt panels, MC cables, solar controller mounted in weatherproof enclosure with fusing. Batteries NOT included
TE-W-602	24VDC Solar Panel only.
TE-W-608	Connection cable from Solar panel or other alternative energy source to TE-Wilbur sampler.

### 12.4 Solar Siting Guidelines

The following map shows average solar hours per day throughout the world. The lighter shades have lower sun hours versus the darker shades

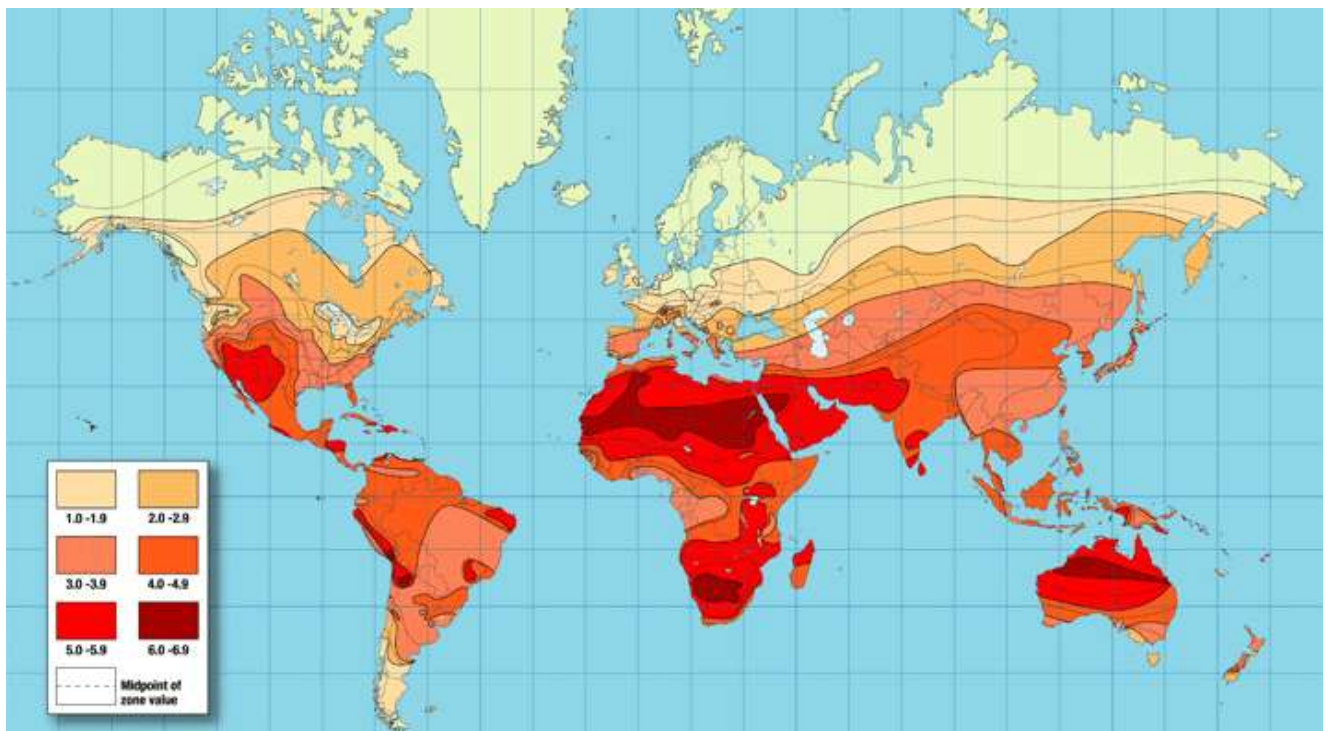



The following map shows the solar radiation across the United States

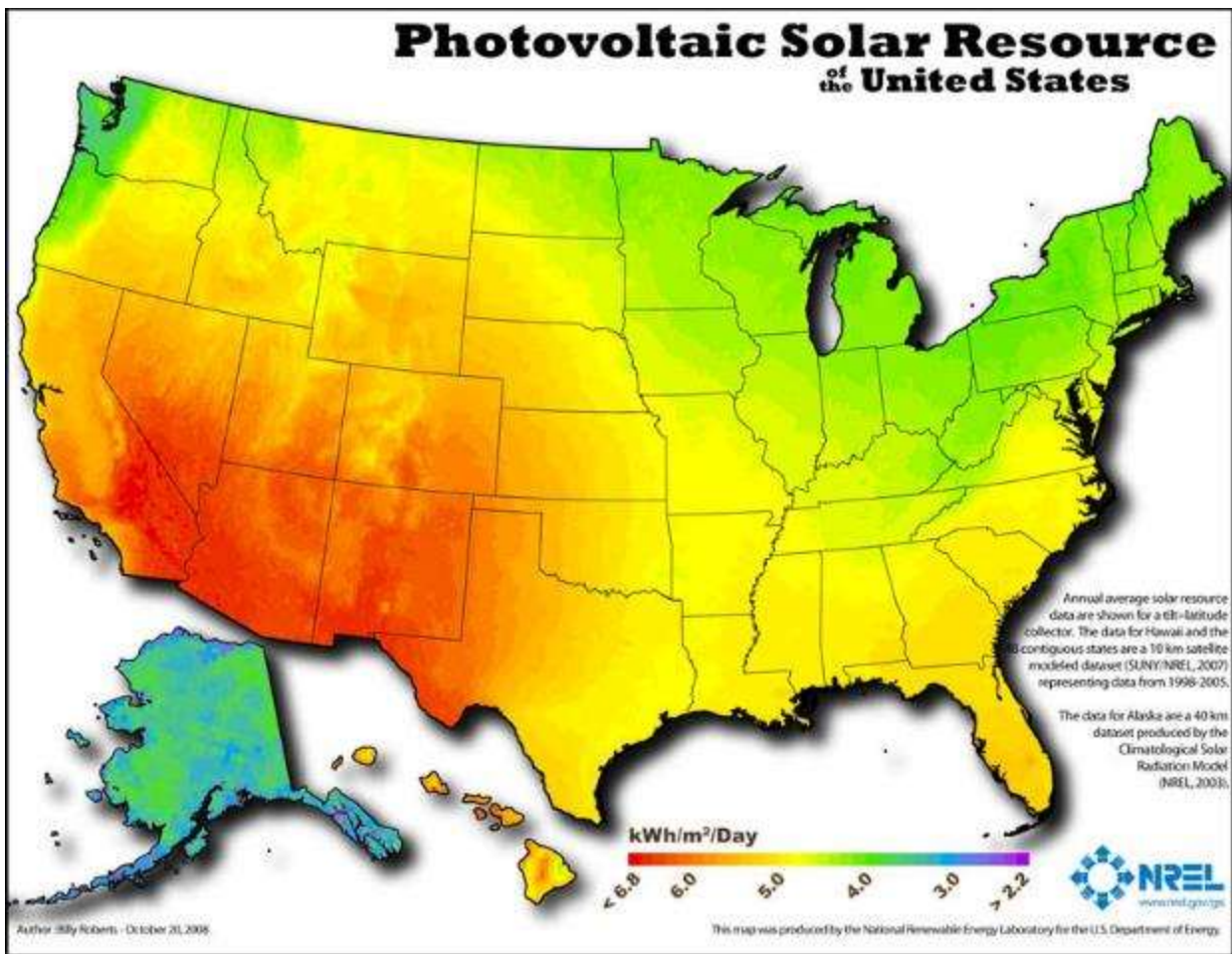

TE-Wilbur Power Requirements at 24VDC:

When sampling	1250mA	30 watts
When idle	625mA	15 watts

Some useful links for Solar applications:

National Oceanic and Atmospheric Administration (NOAA)

<http://www.esrl.noaa.gov/gmd/grad/solcalc/>

National Renewable Energy Laboratory (NREL)

<http://www.nrel.gov/>

## 12.5 Solar Controller Operation

The Solar accessory is controlled from a Morningstar SunSaver MPPT charge controller.

**NOTE:** The instruction manual is included with each solar accessory and should be consulted for proper operation of the solar controller.

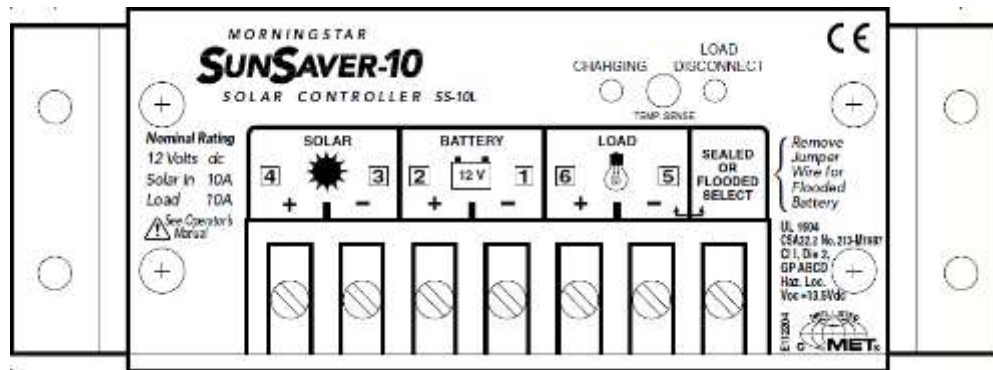

The controller has system status and battery status LEDs. Consult the user manual for LED status indications

## 12.6 Proper Solar Panel Orientation

### Direction to face a solar panel

Solar panels should always face true south if you are located in the northern hemisphere and true north if you are located in the southern hemisphere. ‘True’ North and South are not the same as magnetic north and south. If using a compass you must find out your location’s magnetic declination. There are several websites that are useful for this. The National Geophysical Data Center offers a calculator.

<http://www.ngdc.noaa.gov/geomag-web/#declination>

This website will calculate your latitude and longitude and the magnetic declination at that location. At our facility in Cleves, OH the magnetic declination is 5 Degrees West. So to properly point a solar panel you would use a compass to find magnetic north, then move 5 degrees to the west to find the true north since our facility is located in the northern hemisphere.

This map shows the magnetic declination for the year 2010

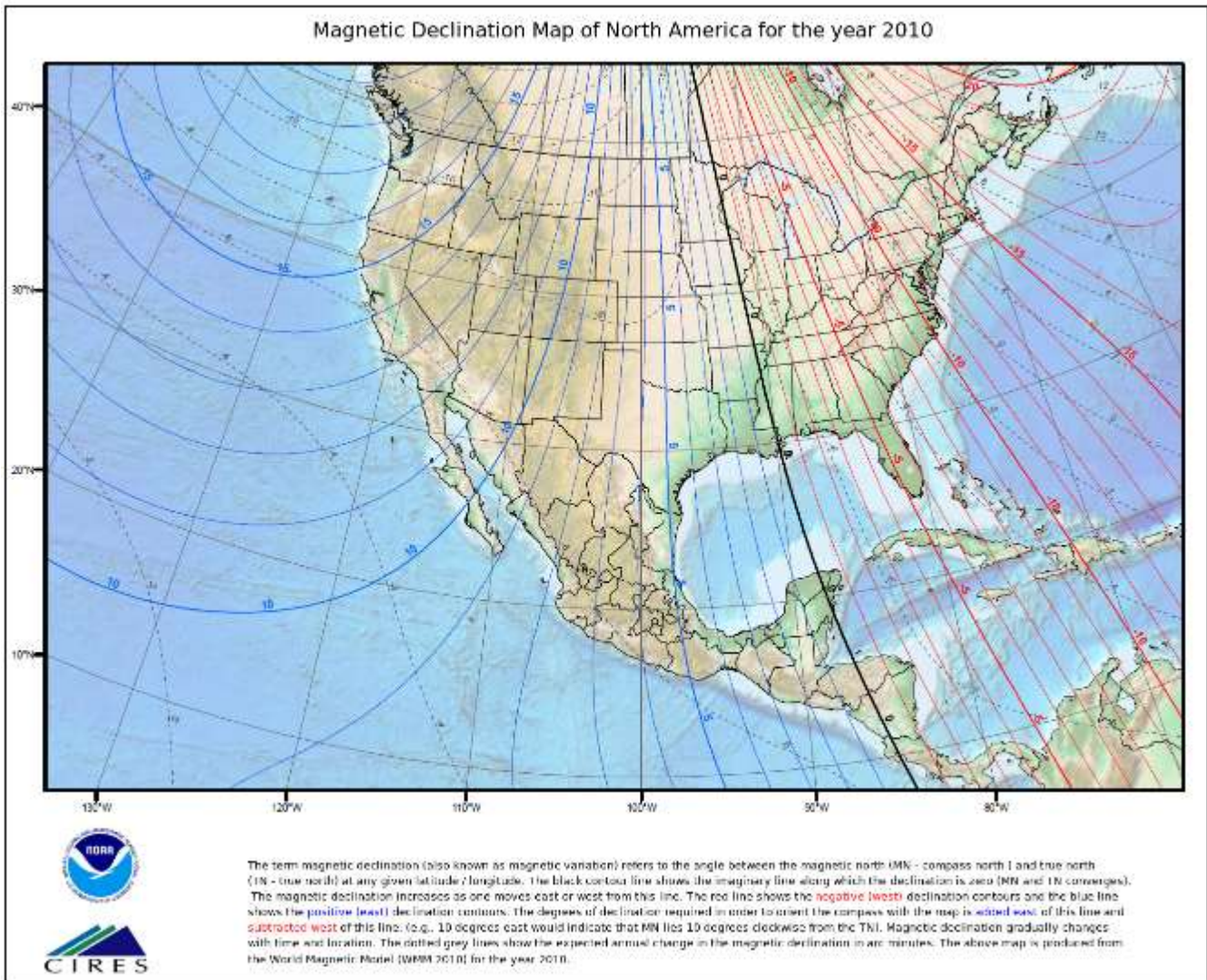

### Proper Solar Panel Tilt

The tilt of the solar panel is important. If setting up the solar panel as fixed, meaning it will not move from summer to winter, use the following guidelines:

To find the angle from horizontal to tilt the solar panel:

#### Latitude

- Below 25°
- Between 25° and 50°
- Over 50°

#### Tilt angle Calculation

- Latitude x 0.87
- Latitude x 0.76 + 3.1°
- Best angle is 45°



This map gives an overview of the proper tilt angle for solar panels around the world:

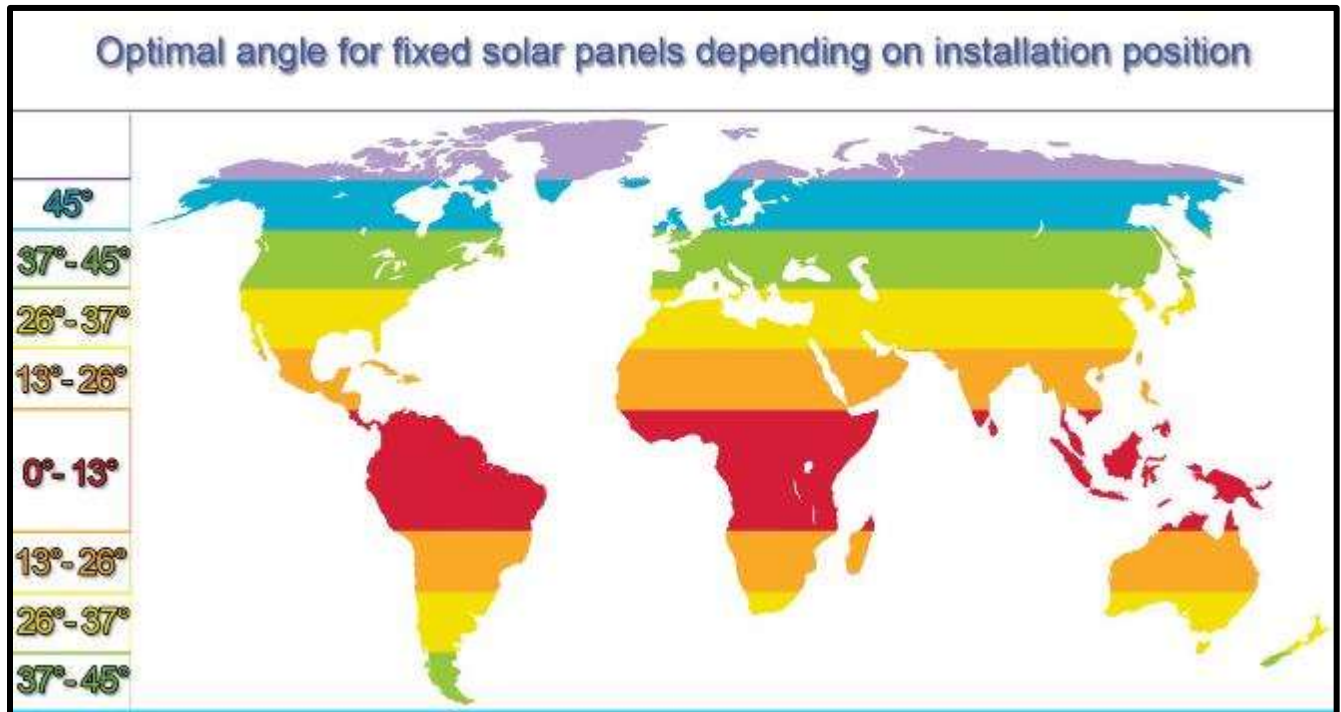

There are also many resources online to assist with getting the right tilt angle for the solar panels:

<http://www.otilt.com/index.php>

<http://solarelectricityhandbook.com/solar-angle-calculator.html>

## 13.0 Maintenance

This section describes the maintenance procedures for the TE-Wilbur sampler.

### 13.1 Electrical System

The TE-Wilbur operates on 120V/230VAC mains power. The system is then converted to 24VDC power which is supplied by a 60watt power supply.

#### Turning on the system

Plug the system into mains power, either 120VAC or 230VAC  
Press the green button on the inside front cover, just below the touch-screen. The button has an internal green LED that will illuminate letting the operator know that mains power is on. When this light is off, mains power has been lost. When this happens, the system will switch to battery power. There will be a notification on the screen that mains power was lost and an entry in the history log.

A battery backup UPS (uninterruptable power supply) is used with 5 amp-hour batteries.

When power is lost, the system will automatically switch over to battery power and will continue to operate. This feature is only to keep a sample running for a few hours if there is an intermittent loss of mains power. If a longer runtime is needed, please refer to section 12.0 Solar / Alternative Energy.

The sealed lead-acid batteries in the system should last approximately 5 years.

Typical Runtime During Sampling:      Approximately 3-4 hours

Typical Runtime Idle:                      Approximately 8-9 hours

Allow the batteries to fully charge by plugging the sampler into mains power for 24 hours.

**Powering off the system**

In order to power off the system, the batteries must be disconnected. To disconnect the batteries perform the following keystrokes:



Pressing this button will disconnect the batteries from the system and allow the system to be powered down completely by removing mains power.

**NOTE:** If mains power is removed and the sampler is running on battery, pressing the disconnect battery button will power down the sampler. **Mains power must be applied to the sampler to power on again.**

The mains electrical connection is a standard IEC-320 plug configuration and is found in the weatherproof box on the side of the sampler.

A 1Amp resettable circuit breaker is located just below the AC inlet plug. If this circuit breaker would trip, it can be reset by pushing the button on the front.



**WARNING** – When powering down the system to perform maintenance, it is important to remove mains power from the sampler by unplugging the cord from the power source. The terminals for the plug and circuit breaker will be energized and could be accidentally touched inside the unit, resulting in a shock hazard.

### Electrical System Layout

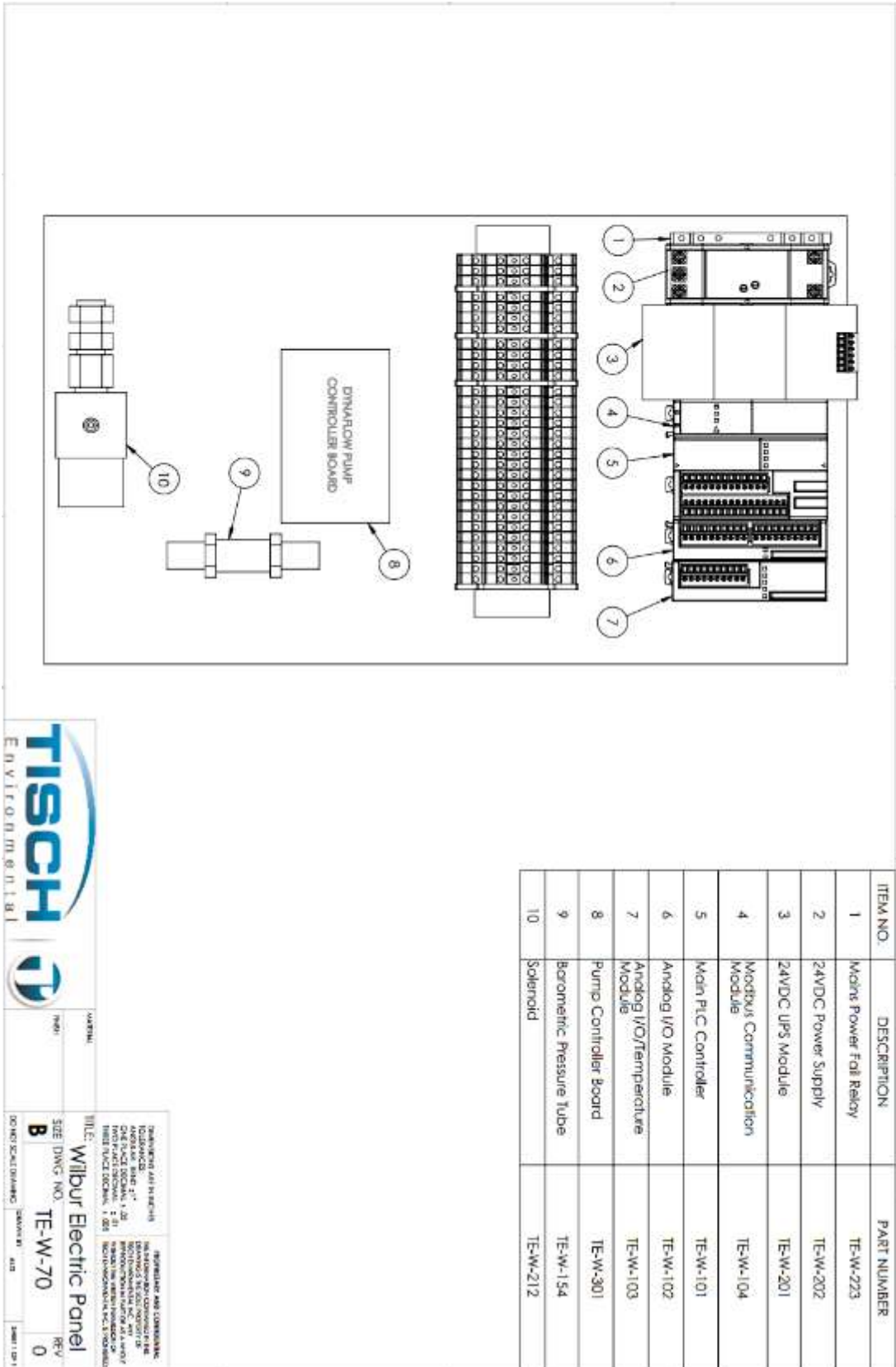

ENVIRONMENTAL

**TITLE:** Wilbur Electric Panel  
**SIZE:** DWG NO. TE-W-70  
**REV:** 0  

 DRAWING MADE BY: BETH H...  
 DESIGNED BY: BETH H...  
 CHECKED BY: BETH H...  
 DATE: 06/11/2015  
 TISCH ENVIRONMENTAL  
 1000 WILBUR DRIVE  
 WILBUR, NC 27586  
 TEL: 919-286-1000  
 FAX: 919-286-1001  
 WWW.TISCH-ENV.COM

## 13.2 Fuse Location and Replacement

There is one fuse used in the sampler and it is located in a fuse holder on the terminal strip left side.



**WARNING** – Before opening covers to perform maintenance, ensure unit is powered down completely. To power down completely, remove mains power and disconnect the battery at:



To replace the fuse perform the following:

1. Open the front, lower cover by removing the 4 screws with a phillips screwdriver.
2. Remove the upper front cover by removing the 4 screws with a phillips screwdriver.
3. Notice the cabling - especially the cable that extends from the PLC on the rear plate to the screen, this cable could become unplugged if the upper panel is pulled away too far from the sampler.
4. The upper plate should be able to be placed on top of the sampler without disconnecting any of the cables.
5. The fuse holder is located on the left side of the terminal strip on the rear panel.
6. Open the fuse holder by pulling down on the top tab of the lever arm.
7. The fuse is located in the lever arm. Remove the fuse and check either visually and/or with a continuity / ohmmeter to see if it has blown.
8. Replace the fuse as needed.
9. Push fuse holder lever arm back into the fuse holder ensuring it is seated correctly.
10. Reinstall upper and lower plates.

### Fuse table

F1 Littlefuse 021702.5HXP (5x20mm glass) 2.5 Amp / 250V

Tisch Environmental fuse part number TE-W-208.



### 13.3 Replacing the Batteries

The battery pack that is utilized in the sampler is 24VDC at 5 amp-hours. It contains two sealed lead acid (SLA) type batteries and can be ordered by part number TE-W-200. When the batteries have failed there will be an alarm that indicates battery failure. There is also an alarm when the batteries have been fully discharged. When this alarm activates, there is only several minutes of battery time before power is lost. If the batteries are not keeping the system energized for very long this is also an indication that the batteries need replacing. When the batteries fail, the sampler will continue to operate as normal, except when there is a mains power loss, the unit will power down completely.

The sealed lead-acid batteries in the system should last approximately 5 years.

Typical Runtime During Sampling:      Approximately 3-4 hours

Typical Runtime Idle:                      Approximately 8-9 hours

To replace the batteries perform the following:



**WARNING** – Before opening covers to perform maintenance, ensure unit is powered down completely. To power down completely, remove mains power and disconnect the battery at:



1. Power down the sampler.
2. Remove the lower front cover by removing the 4 screws with a phillips screwdriver.
3. Locate the cable that is connected to the battery pack. Unplug the battery pack from the unit.
4. Unhook the Velcro straps that secure the battery pack into the battery pack tray.
5. Remove the old battery pack.

**NOTE:** Check with local environmental and recycling agencies for the proper disposal of sealed lead-acid batteries (SLA).

6. Install new battery pack and secure with Velcro straps into the battery pack tray.
7. Plug the new battery pack in to the unit.
8. Reinstall the lower front cover.
9. Allow the batteries to charge a full 24 hours by having unit plugged into mains power.

### 13.4 Replacing the Screen Internal Battery

The internal battery in the screen is critical for proper operation of the sampler. This battery is used to store the configuration of the unit and when it is depleted this information could be lost.

When the battery is low and needs replaced, the following message will appear on the screen:

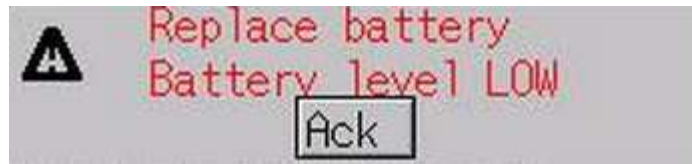

Also, an alarm will be shown in the history log that the internal screen battery needs replaced.

The battery is a standard CR2032 3.3V lithium Ion battery manufactured by several companies such as Duracell, Energizer, Sony and Panasonic. The Tisch Environmental part number for this battery is a TE-W-215.

To replace the internal screen battery, perform the following:



**WARNING** – Before opening covers to perform maintenance, ensure unit is powered down completely. To power down completely, remove mains power and disconnect the battery at:



1. Power down the sampler.
2. Remove the upper front cover by removing the 4 screws with a phillips screwdriver.
3. The battery cover is located on the rear of the touchpanel in the center of the screen.
4. Open the battery cover and remove the old battery
5. Replace with a new battery and close the battery cover
6. Reinstall the upper front cover and secure with the 4 screws
7. Power unit on and acknowledge the replace screen battery alarm

**NOTE:** Check with local environmental and recycling agencies for the proper disposal of Lithium Ion batteries

### 13.5 Sample Pump Maintenance

The sample pump used in TE-Wilbur is a single head diaphragm pump that is powered by a 24VDC brushless motor.

Pump rebuilds are recommended every 3,000 hours of pump operation or when the pump is making extreme noises or is not pumping the correct air flow.

The part numbers for the pump are as follows:

TE-W-300	Entire sample pump with brushless 24VDC motor and single head diaphragm pump.
TE-W-303	Pump rebuild kit that includes the single head diaphragm pump housing assembly, diaphragm replacement, o-ring, stainless washer and flat-head screw.

#### Removing the sample pump

The sample pump can be removed by following these steps:



**WARNING** – Before opening covers to perform maintenance, ensure unit is powered down completely. To power down completely, remove mains power and disconnect the battery at:



1. Remove the lower front plate using a phillips screwdriver.
2. Unplug the pump control cable from the pump control circuit board, noting the direction of the connector onto the board.
3. Unscrew the two screws holding the sample pump plate into the side of the internal side plate.
4. Remove the pump and pump plate, noting the slot the pump plate end seats into.

## Replacing the diaphragm pump

The diaphragm pump can be easily field replaced by following these steps:

Picture showing pump, screwdriver and pump rebuild kit



1. Remove the pump and motor from the pump plate by turning the pump mounting plate over and removing the two screws securing the pump to the pump mounting plate.
2. Using a phillips screwdriver, remove the four screws that secure the pump head to the motor body.



3. Discard old pump head.
4. Now remove the screw that holds the diaphragm on the pump body.



5. Discard the old diaphragm, screw, o-ring and washer.
6. Replace the o-ring and the stainless steel washer that are on the pump shaft.

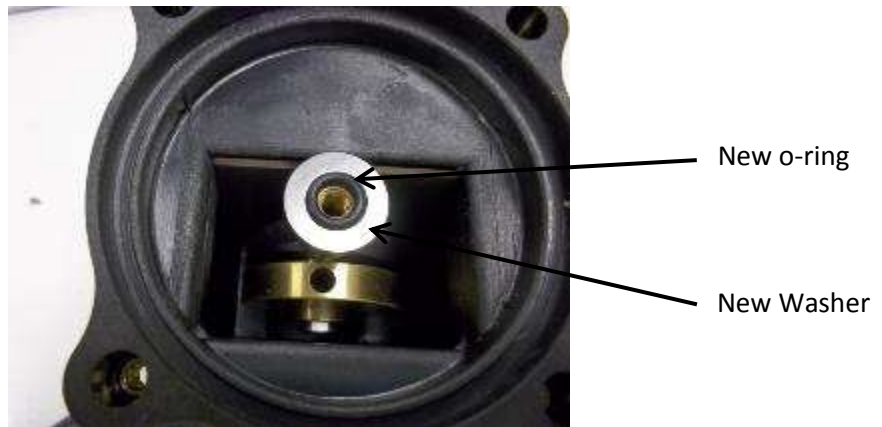

7. Carefully center the motor shaft in the center of the body and press the new diaphragm onto the motor shaft aligning the hole for the screw.



8. Place the new screw into the hole and tighten the screw with the screwdriver.

9. Place the new pump head over the diaphragm and line up the four bolt holes.
10. Tighten the four bolts.



### **Inserting the pump back into the unit**

The pump can be easily inserted back into the unit by following these steps:

1. Make sure the pump is mounted on the pump bracket.
2. Note the slot that is located on the left inside of the enclosure, the ear of the pump plate gets inserted into this slot.
3. Secure the pump plate with the two 8-32 stainless steel bolts.
4. Place lower front cover back in place and secure with 4 bolts.

## 13.6 Filter Holder Maintenance

The filter holder is maintenance free with the exception of tightening or loosening the mechanism if the system should become loose or is having an issue passing a leak check.

There are o-rings on the top and bottom mate pieces that seal the filter cassette, inspect these for wear or damage if there appears to be a leak. Replace if needed. Tisch Environmental part number TE-W-FH6 for (2) filter holder o-rings.

### **To replace the filter holder o-rings:**

- Remove the filter holder from the enclosure by removing the downtube, the four bolts on the filter holder plate and disconnecting the sample tubing to remove the filter holder from the enclosure.
- Remove the 6 screws on the top of the filter holder to remove the top mate piece.
- The o-ring can be removed with a small thin flat-blade screwdriver by pushing the screwdriver into the o-ring groove and prying the o-ring from the groove.
- Replace with a new o-ring and push the o-ring into the groove with your finger, ensure it gets seated entirely.
- Using the small thin flat-blade screwdriver pry the bottom mate o-ring from the groove.
- Replace with a new o-ring and push the o-ring into the groove with your finger, ensure it gets seated entirely.
- Place top mate back on top of the filter holder aligning the 6 holes and secure with the 6 bolts.

The filter holder should be cleaned on a monthly basis to keep stray particulate matter from affecting sampling results. The inside of the bottom and top mate and the top tube can be cleaned with distilled water or a general purpose cleaner and a soft cloth.

See section 4.4, adjusting the filter holder for information on making adjustments to the filter holder mechanism.



### 13.7 UPS System Replacement

If the UPS needs replaced, perform the following:

The part number for the UPS module is TE-W-201.



**WARNING** – Before opening covers to perform maintenance, ensure unit is powered down completely. To power down completely, remove mains power and disconnect the battery at:



1. Remove both the upper and lower left plates using a phillips screwdriver.
2. The UPS module is located in the top left corner on the rear plate.

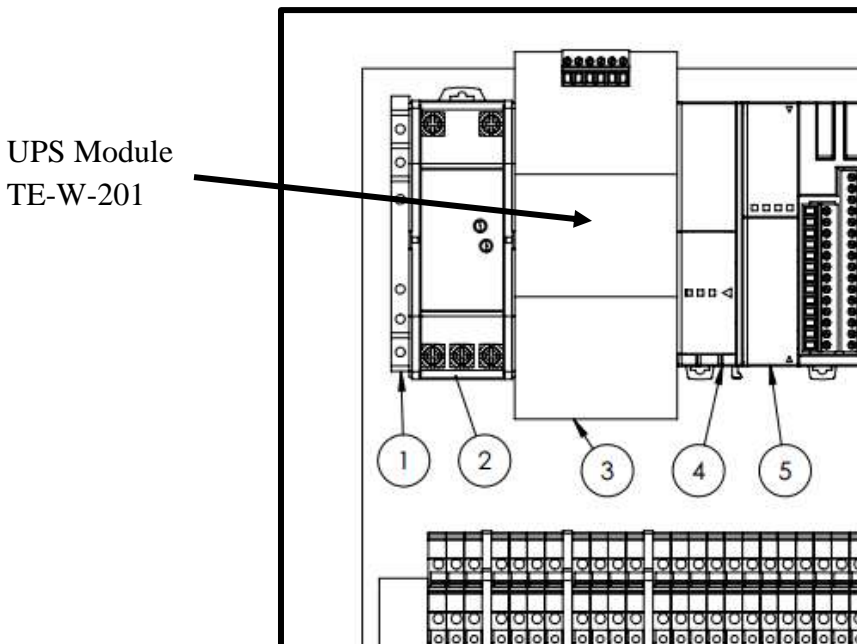

3. There are wires that enter on the top of the UPS and on the bottom of the UPS.
4. On top there are (4) wires on TB2 terminals 1 through 4 that are the alarm outputs for battery fail and battery discharge that route over to the controller. Label each of these wires and unscrew the terminals and remove the (4) top wires.



- On the bottom of the UPS there are (4) wires on TB1, 2 wires for DC+ and DC- and 2 wires for Battery + and Battery -. Label each of these wires and unscrew the terminals and remove the (4) bottom wires.

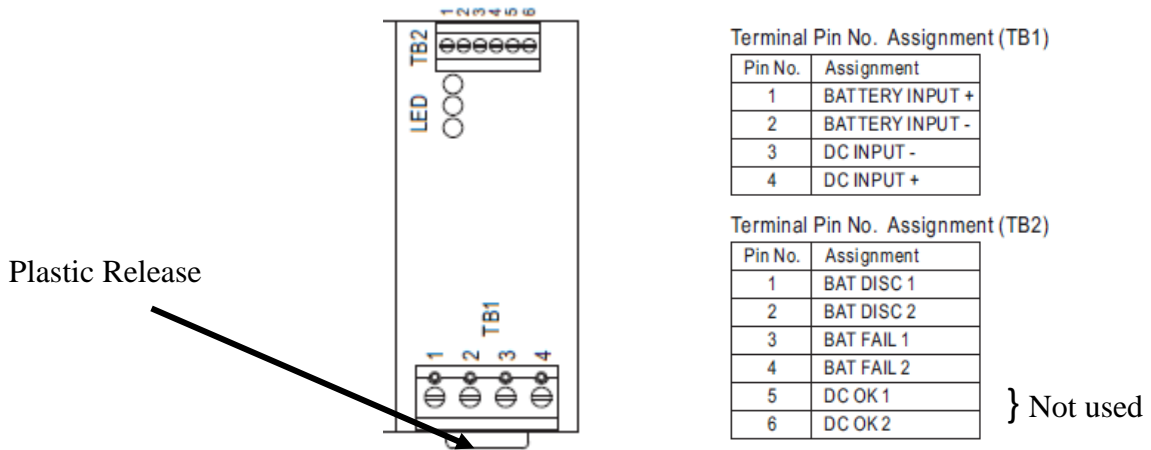

- Notice the plastic release at the very back, on the bottom of the UPS module. Using a flat-head screwdriver push this lip downward, releasing the UPS module from the DIN rail. Tilt the module towards you and remove from the enclosure.
- To install a new UPS module, you must first hook the top onto the DIN rail, then push downward to secure the UPS module onto the DIN rail. You will hear and feel a ‘click’ as the UPS module is seated onto the DIN rail properly.
- Reattach the wires on TB1 and TB2 (4) wires on each top and bottom terminals.
- Reinstall the upper and lower front panel and power unit on.
- Test the UPS by connecting charged batteries and disconnecting power. The UPS should switch and run on the batteries.

### 13.8 Power Supply Replacement

If the 24VDC power supply needs replaced, perform the following:

The part number for the power supply is TE-W-202.



**WARNING** – Before opening covers and maintaining unit, ensure unit is powered down completely. To power down completely, remove mains power and disconnect the battery at:



1. Remove both the upper and lower left plates using a Philips screwdriver.
2. The power supply is located at the top on the rear plate between the controller and UPS module.

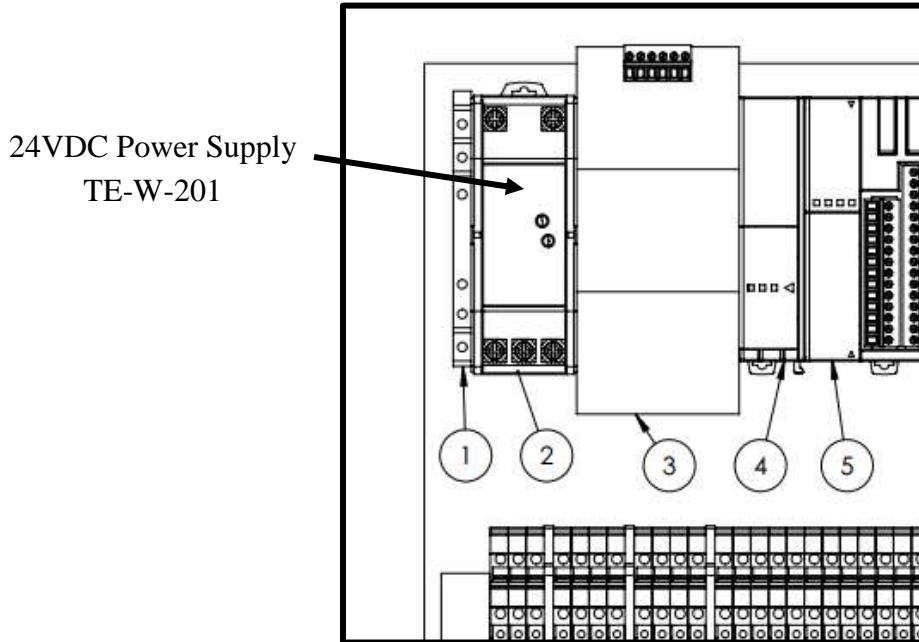

3. There are wires that enter on the top of the power supply and on the bottom of the power supply.

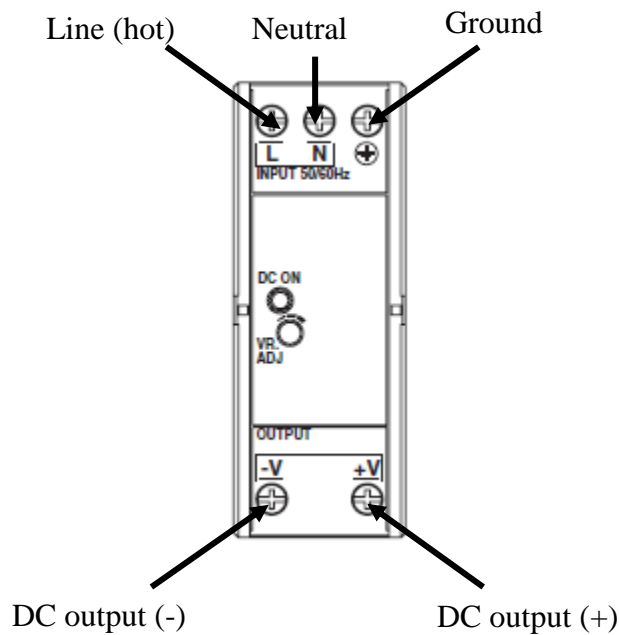

4. On top there are (3) wires on top for Line Voltage (hot), Neutral and Ground. These will be colored black, white and green respectively. Unscrew the terminals and remove the (3) top wires.
5. There are (2) wires on the bottom for DC output (+) and (-), label these and unscrew the terminals and remove the bottom (2) wires.
6. The Power supply has a plastic clamp on the bottom at the rear of the unit that is used to attach the unit to the DIN rail. Using a small flat-blade screwdriver insert the blade into the hole on the clamp and push downwards. The clamp will 'click' into the open / downward position.

**Removal**

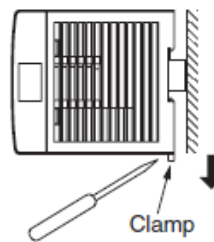

7. Now the power supply can be removed by tilting upwards and removing from the DIN rail.
8. To insert a new power supply, the top notches must be attached to the DIN rail first, then push the bottom towards the DIN rail until the unit 'clicks' into place.

**Mounting**

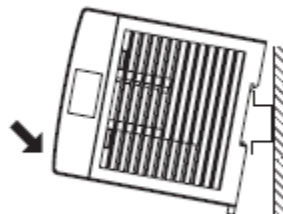

9. Reinstall the (3) top wires for the hot, neutral and ground by placing the wire into terminal and screwing tight with screwdriver.
10. Reinstall the (2) bottom wires for the DC output.
11. Now that the power supply is installed and wired, it must be checked for proper voltage.
12. Turn on the unit. The power supply light on the front should be on and green, noting proper operation. If this light is not on check all wiring.
13. Place a DC voltage meter on the DC output of the power supply, red on positive and black on negative.

14. The voltage of the power supply needs to be set at around 27 volts. Read the voltage on the voltage meter, if the voltage is not 27 volts the voltage must be adjusted.

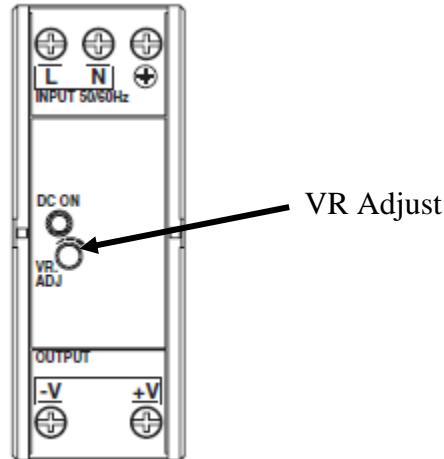

15. To adjust the voltage, turn the VR Adjust knob clockwise to increase and counter-clockwise to decrease. Set the voltage of the power supply at 27.0 volts. This voltage is necessary to provide proper charging voltage for the batteries.
16. Reinstall the upper and lower front panel and power unit on.

### 13.9 Controller Replacement

If the Programmable Logic Controller needs replaced perform the following:

The part number for the PLC is made up of the following modules:

TE-W-101	Main Controller Module
TE-W-102	Analog input module
TE-W-103	Analog input / output module
TE-W-104	Modbus communication module



**WARNING** – Before opening covers to perform maintenance, ensure unit is powered down completely. To power down completely, remove mains power and disconnect the battery at:



1. Remove both the upper and lower left plates using a Phillips screwdriver.
2. The controller is located at the top on the rear plate on the right side.

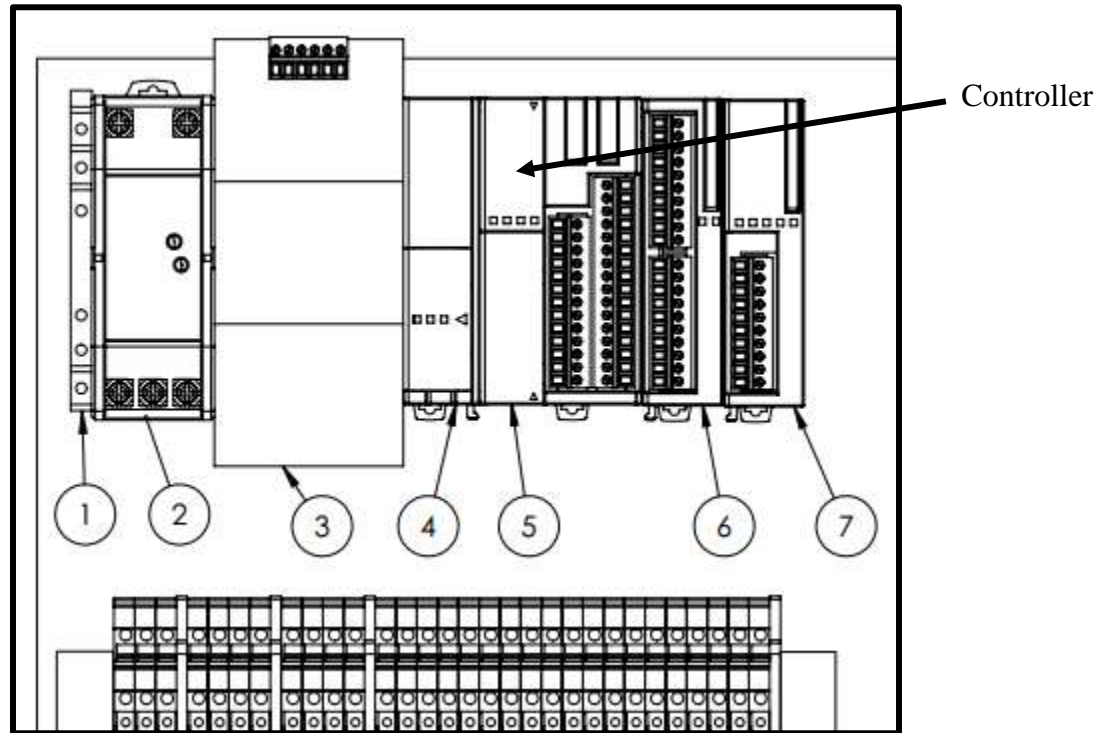

3. Unplug the cable from the screen.
4. There are two wires that enter the controller at the bottom for DC power, label these wires and remove them.

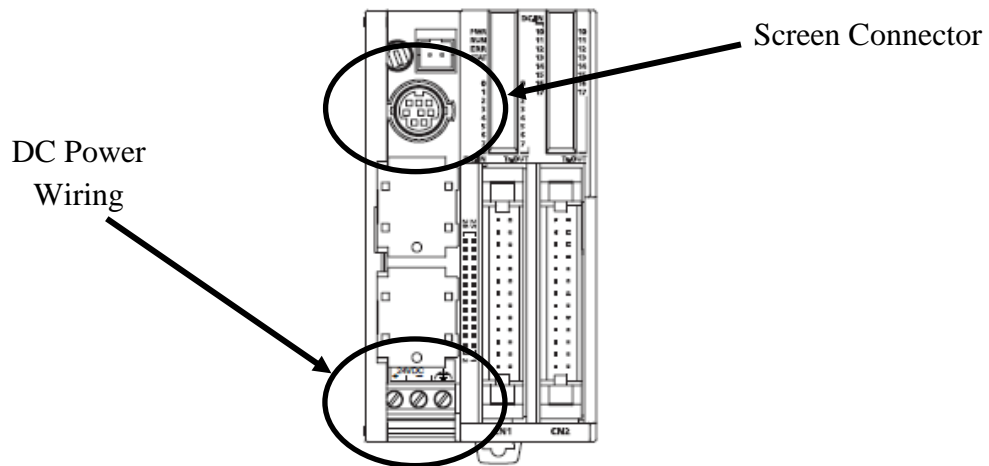

- The wiring of the Modbus module must now be removed. The Modbus module is located here:

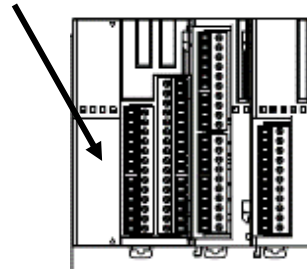

- The Modbus module has (2) wires, label each wire and remove them by unscrewing the terminal and removing the wire.
- The rest of the wiring is modular and can be removed by grasping each terminal block in the center and pulling straight out.
- Now that all the wiring is removed, notice the clamps at the bottom of the controller. There are (3) of them.

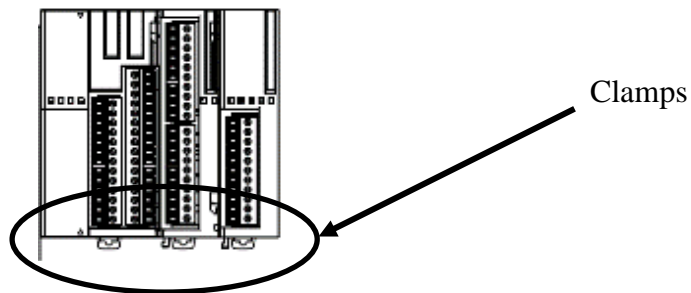

- Using a small flat-blade screwdriver insert the blade into the hole on the clamp and push downwards. The clamp will 'click' into the open / downward position.

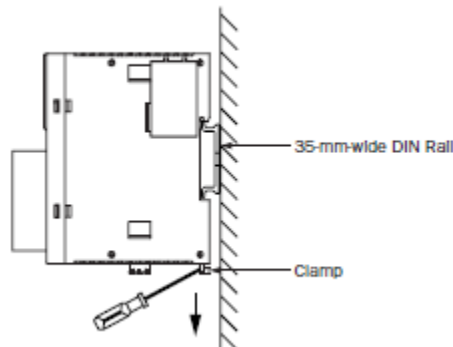

10. Now the controller can be removed by tilting upwards and removing from the DIN rail.

11. The controller consists of (4) modules:

TE-W-101	Main Controller Module
TE-W-102	Analog input module
TE-W-103	Analog input / output module
TE-W-104	Modbus communication module

12. Each module can be removed or replaced individually. Notice the latch in the center of the modules. When the latch is in the downward position, the modules can be pulled apart. When the latch is in the upward position the modules cannot be pulled apart.

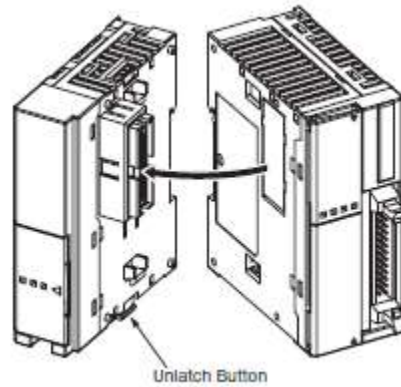

13. Replace each module or entire controller assembly as required. When modules are all put back together, ensure all the latches are in the upward position.

14. Place the controller assembly onto the DIN rail. The top must first be attached, then the bottom can be pushed onto the DIN rail until a 'click' is heard denoting the controller is properly seated onto the DIN rail.

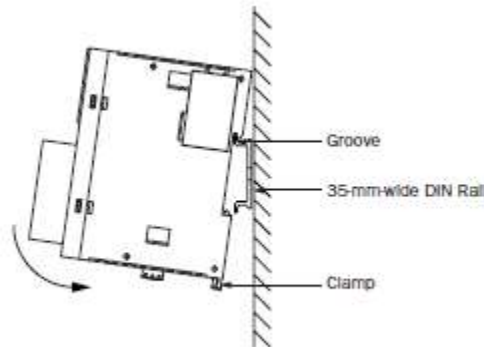

15. Once the controller is seated on the Din rail properly you must now reinstall the wiring.
16. Reinstall the (2) Modbus wires onto the Modbus module securing by tightening the terminal screw.
17. Reinstall the (2) DC Power wires onto the controller securing by tightening the terminal screw.
18. Reinstall the (5) connectors in their proper locations on the controller assembly.
19. Plug the communication cable from the screen back into the controller port on the front.
20. Reinstall the upper and lower front panels and power unit on.

### 13.10 Flowmeter Replacement

If the thermal mass flowmeter needs replaced, perform the following:

The part number for the thermal mass flowmeter is TE-W-150.



**WARNING** – Before opening covers to perform maintenance, ensure unit is powered down completely. To power down completely, remove mains power and disconnect the battery at:



1. Remove both the upper and lower left plates using a Phillips screwdriver.
2. The thermal mass flowmeter is located on the inside right wall (center divider) of the enclosure.
3. Unplug the connector on the flowmeter by pushing down on the tab on top and pulling outwards.

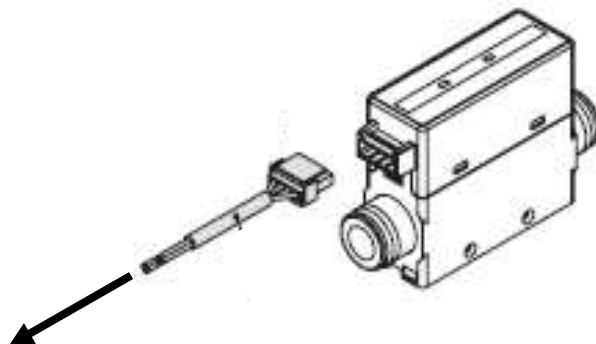



4. The flowmeter has a 17mm twist-nut for the process connection. You will need to hold the 17mm nut as you turn the compression fitting with a 9/16 wrench to loosen the compression fitting.
5. Loosen each compression fitting and disconnect the entry and exit tubing from the flowmeter.
6. Remove the two screws and nuts that secure the flowmeter to the sidewall.
7. Remove flowmeter.
8. Remove the compression fittings from the old flowmeter and install in the new flowmeter – make sure to use thread tape on the threads to ensure a leak-free seal.
9. Place new flowmeter in place and secure to the sidewall with the screws and nuts.
10. Connect the entry and exit tubing and tighten 1 and ¼ turns after the compression fitting is finger tight.
11. Plug connector back into flowmeter.
12. Reinstall the upper and lower front panels and power unit on.
13. See section 7.5 to perform a calibration of the flow system.

### 13.11 Pressure Sensor Replacement

If the pressure sensor needs replaced, perform the following:

The part number for the pressure sensor is TE-W-153.



**WARNING** – Before opening covers to perform maintenance, ensure unit is powered down completely. To power down completely, remove mains power and disconnect the battery at:



1. Remove both the upper and lower left plates using a Phillips screwdriver.
2. The pressure sensor is located on the inside right wall (center divider) of the enclosure. It is downstream of the flowmeter.
3. Remove the compression fittings on the tee that the flowmeter is screwed into using a 9/16 wrench and disconnect the entry and exit tubing.

4. Remove the (2) screws that secure the clamp that secures the pressure to the sidewall of the enclosure.
5. Unplug the pressure sensor connector and remove the pressure sensor.
6. Remove the tee from the old pressure sensor and install on the new pressure sensor. Use thread tape on the male thread of the new pressure sensor to ensure a leak-free seal.

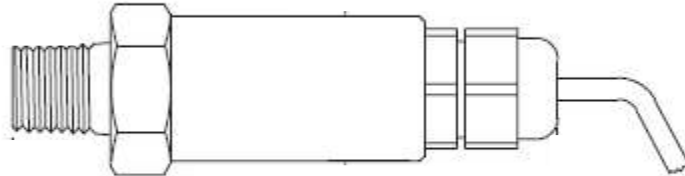

7. Install the new pressure sensor on the sidewall with the clamp and screws.
8. Plug pressure into pressure sensor connector.
9. Reinstall upper and lower left panels and turn power on.
10. Refer to section 7.8 to zero the pressure sensor.

### 13.12 Barometric Pressure Sensor Replacement

If the barometric pressure sensor needs replaced, perform the following:

The part number for the barometric pressure sensor is TE-W-154.



**WARNING** – Before opening covers to perform maintenance, ensure unit is powered down completely. To power down completely, remove mains power and disconnect the battery at:



1. Remove both the upper and lower left plates using a Phillips screwdriver.

The barometric pressure sensor is located on the back of the panel towards the right side and attached to the back panel with a stainless steel strap.

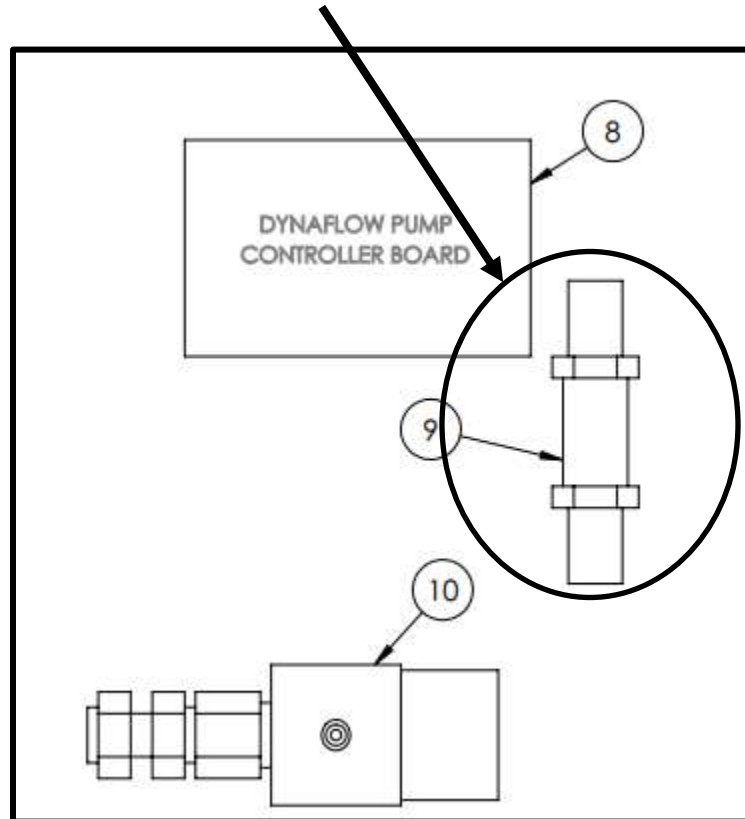

2. Remove the wires on terminal 9, 10 and 11. They should be white, black and red respectively.
3. Remove the 8-32 screw securing the clamp to the back panel.
4. Remove the barometric pressure sensor.
5. Install new barometric pressure sensor and secure to the back panel with the clamp and screw.
6. Terminate the white wire on terminal 9, the black wire on terminal 10 and the red wire on terminal 11.
7. Reinstall the upper and lower left panels and power unit on.
8. See section 7.3 to perform a full calibration of the new barometric pressure sensor.

### 13.13 Filter Temperature Probe Replacement

If the filter temperature probe needs replaced, perform the following:

The part number for the filter temperature probe is TE-W-152.

1. Unplug the filter temperature probe connector.
2. Unscrew the filter temperature probe from the thermowell on the filter holder.
3. Install new filter temperature probe and connect to filter temperature connector.
4. Acknowledge the filter temperature probe was unplugged alarm.
5. See section 7.2 to perform a calibration of the filter holder temperature sensor.

Illustration showing filter temperature probe

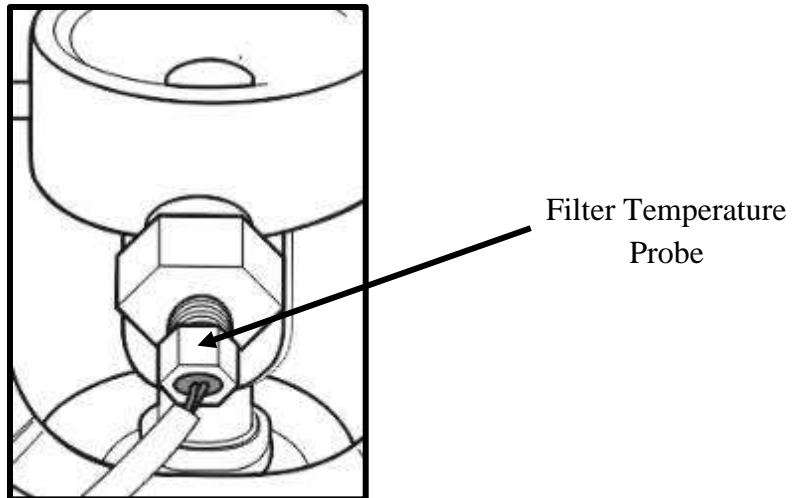

### 13.14 Ambient Temperature Replacement

If the ambient temperature probe needs replaced, perform the following:

The part number for the ambient temperature probe with radiation shield is TE-W-151.

1. Unplug the ambient temperature probe from the connector located on the left side of the enclosure.

- Remove the (2) 1/4-20x5/8” bolts that secure the radiation shield bracket to the enclosure.

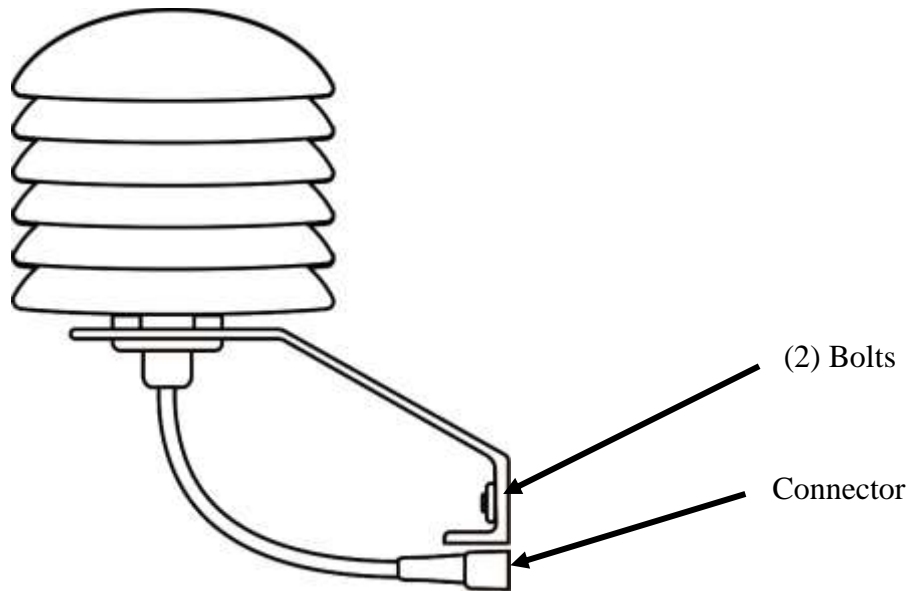

- Install new radiation shield with ambient temperature probe onto the enclosure with the (2) bolts.
- Plug the temperature probe into the socket on the left side of the enclosure.
- Acknowledge the ambient temperature probe was unplugged alarm.
- See section 7.1 to perform a calibration of the ambient temperature sensor.

### 13.15 Solenoid Replacement

If the solenoid needs replaced, perform the following:

The part number for the solenoid is TE-W-212.



**WARNING** – Before opening covers to perform maintenance, ensure unit is powered down completely. To power down completely, remove mains power and disconnect the battery at:



- Remove both the upper and lower left plates using a Phillips screwdriver.

The solenoid is located on the back of the panel towards the bottom right side

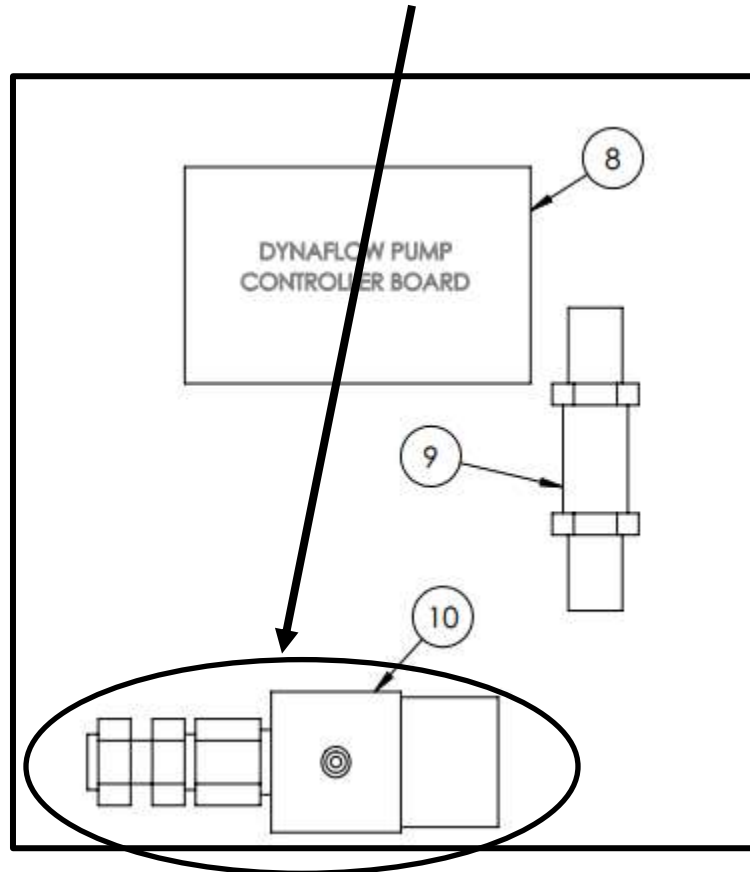

2. Remove the compression fittings from the inlet and outlet using a 9/16" wrench.
3. Remove the wiring on terminals (3) and (-) of the solenoid.
4. Remove the two screws that secure the solenoid to the back panel and remove the solenoid.
5. Remove the compression fittings from the solenoid.
6. Install the compression fittings onto the new solenoid using thread tape on the connector threads to ensure a leak-free seal.
7. Install the new solenoid onto the back panel using the two screws.
8. Wire the solenoid to terminals (3) and (-) **NOTE:** there is no concern with polarity either wire from the solenoid can be terminated on either terminal.

9. Connect the compression hose fittings to the inlet and outlet of the solenoid.
10. Reinstall the upper and lower right plates and turn power on.

### 13.16 Pump Controller Replacement

If the pump controller needs replaced, perform the following:

The part number for the pump controller is TE-W-301 with the TE-W-302 pump controller cable.



**WARNING** – Before opening covers to perform maintenance, ensure unit is powered down completely. To power down completely, remove mains power and disconnect the battery at:



1. Remove both the upper and lower left plates using a Phillips screwdriver.

The pump controller is located on the back of the panel towards the bottom left side.

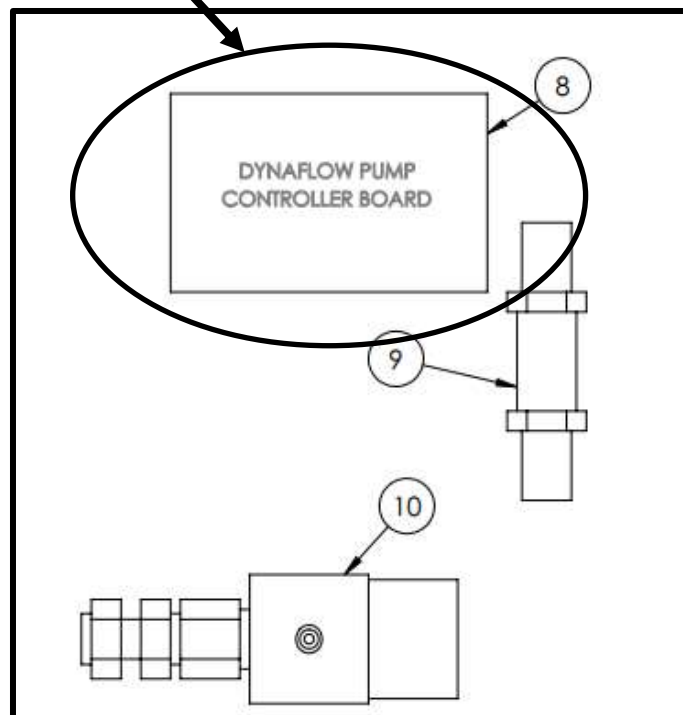

2. There are (3) connectors on the pump controller board, one for 24VDC, the pump connection and the other for the control signal. Unplug the three connectors.

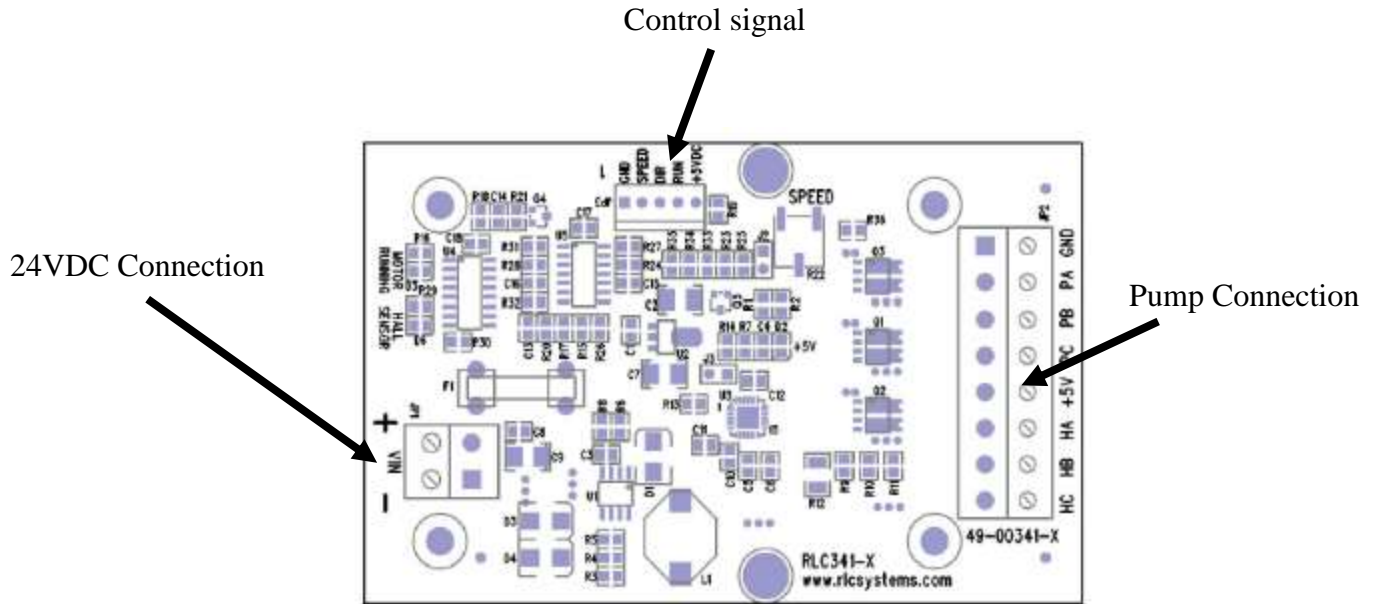

3. Remove the (4) 6-32x3/8" screws that secure the board to the back panel.
4. Install a new pump controller board and secure with the (4) screws.
5. Plug connectors back into board.
6. Reinstall the upper and lower fronts panel and power unit on.



### 13.17 Touch Screen Replacement

If the touch screen needs replaced, perform the following:

The part number for the touch screen is TE-W-100 with the following related part numbers:

- TE-W-106 32MB SD Card
- TE-W-105 Cable from screen to controller
- TE-W-207 USB interconnection cable
- TE-W-216 3ft RJ45 patch cable



**WARNING** – Before opening covers to perform maintenance, ensure unit is powered down completely. To power down completely, remove mains power and disconnect the battery at:



1. Remove both the upper and lower left plates using a Phillips screwdriver.
2. Turn the upper plate over and disconnect the following connectors on the screen:

- The 24VDC power to the screen
- The communication cable to the controller
- The Ethernet cable
- The USB interconnect cable

3. Remove the SD card from the side by pressing it in to eject, then pulling out completely.

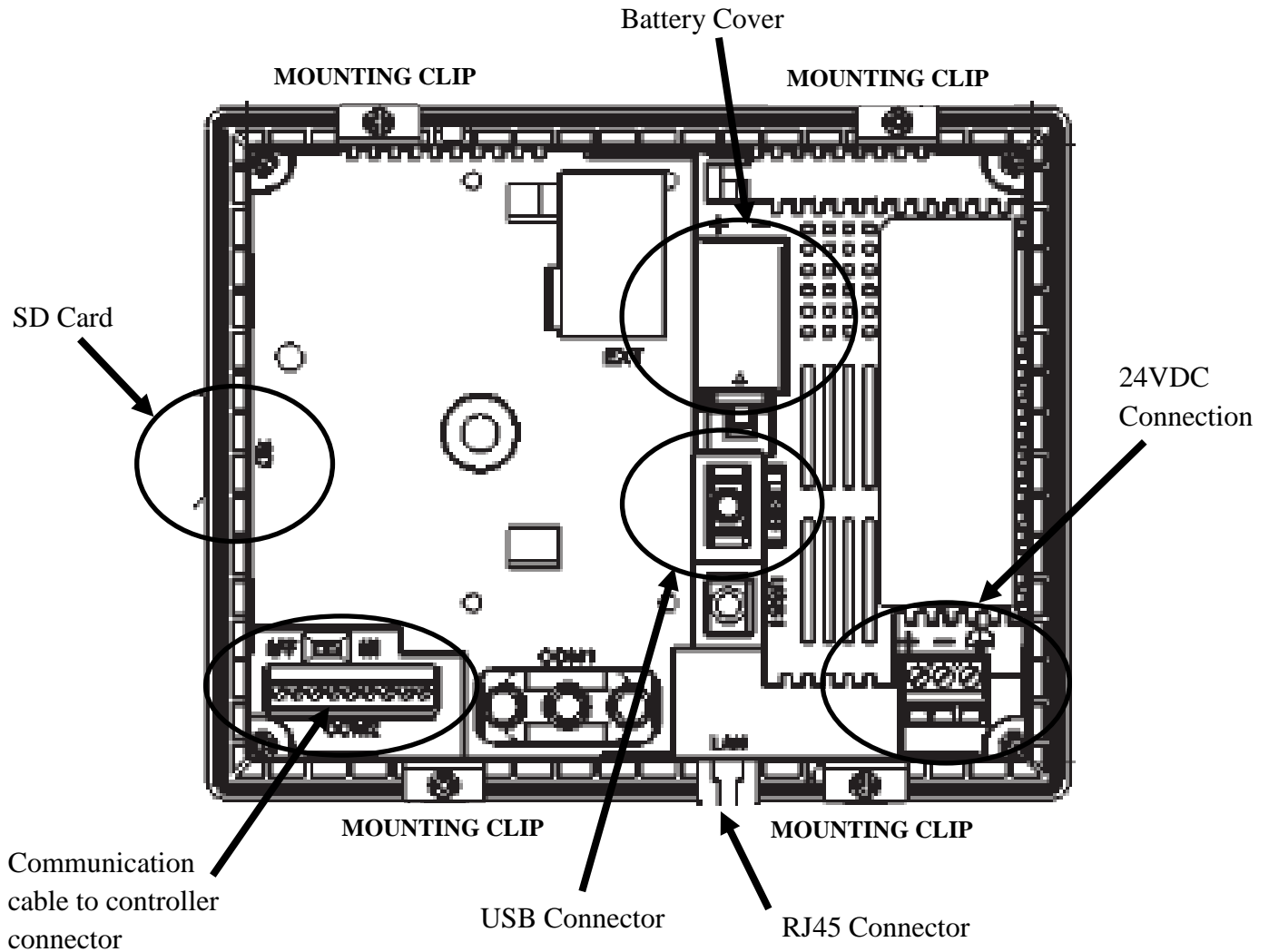

- Using a Phillips screwdriver, unscrew the (4) mounting clips. There are two on the top and two on the bottom of the screen.

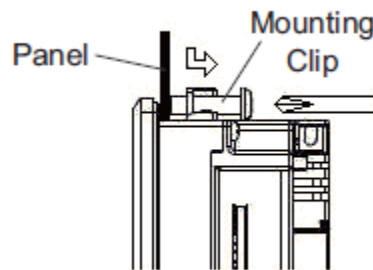

- The mounting clips will snap out of the slots on the screen. Snap out all four of the mounting clips and pull the screen out of the upper front panel from the front.

6. Label the wires on the 24VDC power connection. Unscrew the terminal screws and remove the wires from the 24VDC connection along with the connector.

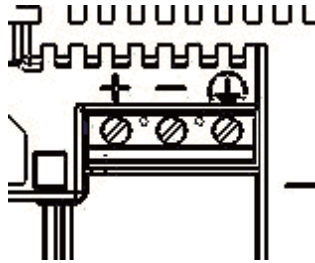

7. Install the 24VDC wires and connector onto the new screen by placing wires in their terminal and tightening the terminal screw.
8. Install new screen through the front of the panel and using the clips, secure to the panel.

**NOTE:** Do not over tighten the clips, otherwise the screen may warp and cause a wrinkle on the display. These need to be 0.2 to 0.3 N·m of torque.

9. Install the SD card on the side.
10. Connect the 24VDC power connector, communication cable to the controller, USB interconnect cable and Ethernet cable.
11. Reinstall the upper and lower front panels and power unit on.

### 13.18 Power Button Replacement

If the power button needs replaced, perform the following:

The part number for the power button is TE-W-206.



**WARNING** – Before opening covers to perform maintenance, ensure unit is powered down completely. To power down completely, remove mains power and disconnect the battery at:



1. Remove both the upper and lower left plates using a Phillips screwdriver.
2. Turn the front panel over and unplug the two connectors that are wired to the power button.
3. Notice the yellow locking lever on the back of the power button, turn this to the left to release the contact blocks from the LED portion of the button.

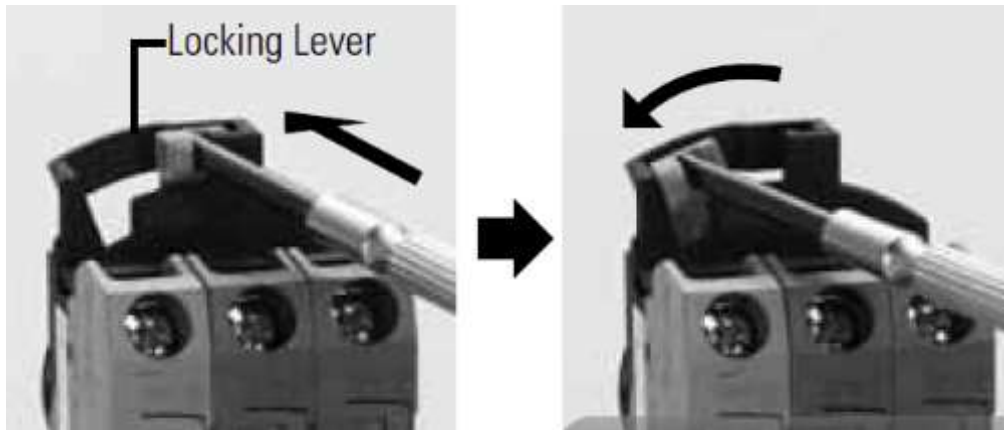

4. On the new pushbutton, remove the contact blocks from the pushbutton housing by performing the same step as above.
5. Remove each wire from the old terminal blocks and place into the new terminal blocks, ensuring each wire is terminated in the same identical terminal location.
6. Now remove the circular LED of the old pushbutton from the panel by using pliers to remove the locking ring and pulling the pushbutton housing out from the front.

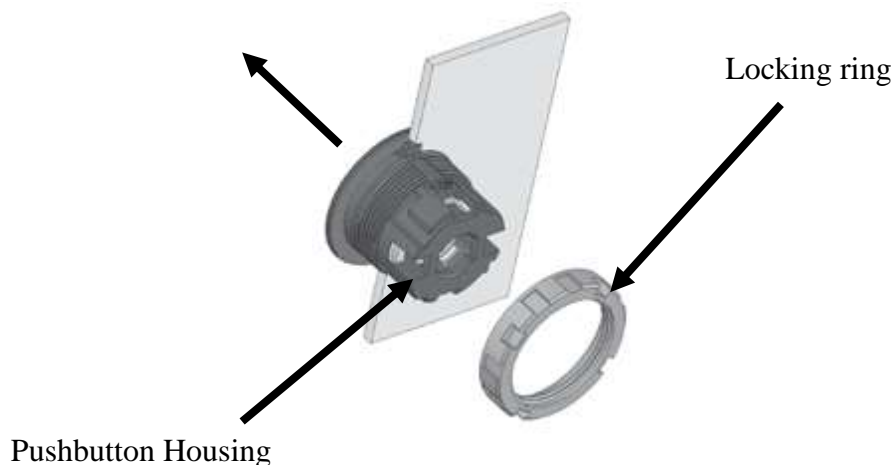

7. Place the new pushbutton housing that you removed the contact blocks from in step 4 into the cutout in the panel, noting the notched hole in the cutout. The notch on the pushbutton must be seated into the notch in the panel cutout.

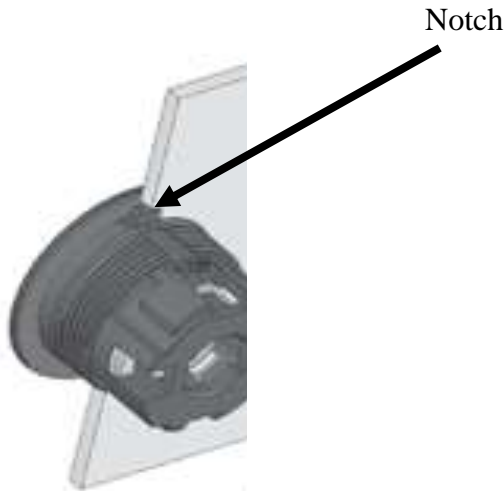

8. Screw on the new locking ring and tighten with pliers. Do not over-tighten as you could strip the plastic threads on the pushbutton.
9. Place the contact blocks onto the pushbutton housing and push the yellow locking lever all the way to the right until you hear and feel a 'click, locking the contact blocks onto the pushbutton housing.
10. Push the button on the pushbutton a few times ensuring proper operation of the switch.
11. Connect the two power in and out connectors.
12. Reinstall the upper and lower front panels and power unit on.

### 13.19 Power Fail Relay Replacement

If the power fail relay needs replaced, perform the following:

The part number for the power fail relay is TE-W-214.



**WARNING** – Before opening covers to perform maintenance, ensure unit is powered down completely. To power down completely, remove mains power and disconnect the battery at:



1. Remove both the upper and lower left plates using a Phillips screwdriver.
2. The power fail relay is located on the right side of the rear panel.

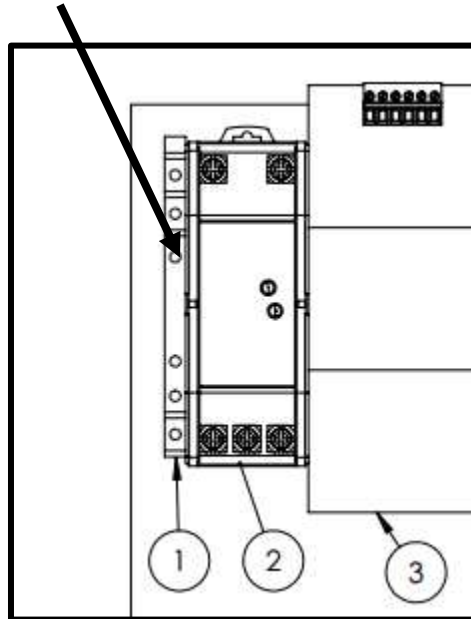

3. Mark the (4) wires that are located on the relay and remove them by pushing down on the slot with a small flat-head screwdriver – the terminals are spring-loaded, so push down and pull the wire out. Remove (4) wires from the power fail relay.
4. The relay can be removed from the DIN rail by placing a small flat-head screwdriver into the plastic slot at the bottom of the relay where it is attached to the DIN rail. Pull this outward and up, unlatching it from the DIN rail.

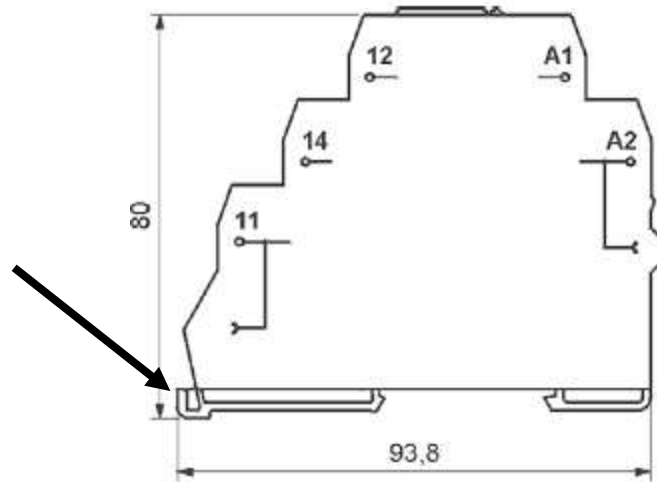

5. Install the new relay onto the DIN rail – it is installed in the same manner as the controller by placing the top part into the DIN rail groove and pushing down until a ‘click’ is heard and felt.

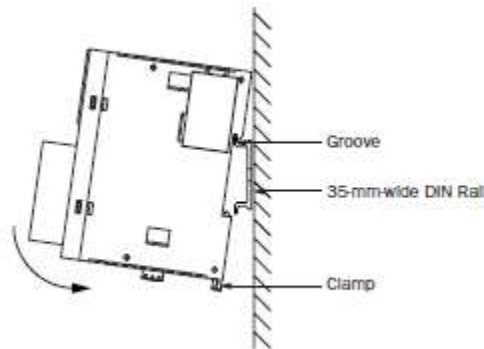

6. Reattach the wires by pushing down on the slot with a small flat-head screwdriver and pushing the wire into the terminal. The wiring diagram is as follows:

Terminal	Connection
A2	Neutral
A1	Hot
11	DC (-)
12	Controller TB1 Terminal 3

7. Reinstall the upper and lower front panels and power unit on.

## 13.20 Louver Filter Media Replacement

The filter media inside the louvers on the right side of the enclosure will need checked quarterly for buildup of dirt and debris.

The replacement part number for the louver filters are TE-W-232

To replace the louver filter media follow these steps:

1. Using a small flat-blade screwdriver, pry the corner of the louver from the louver housing.
2. The louver cover will snap out of the housing
3. Replace each of the filter louver filter media with new media.
4. Push the louver cover back onto the louver housing, snapping it into place.



## 14.0 Troubleshooting

This section explains methods to troubleshoot various conditions and alarms with the TE-Wilbur sampler.



**WARNING** – Maintenance should only be performed by trained individuals. This troubleshooting section assumes the person that is performing the troubleshooting steps is trained to recognize electrical hazards.



**WARNING** – Some troubleshooting techniques will require that mains power is ON while the front covers are removed. Only an electrically trained person should be performing these tasks and care should be taken to prevent electrical shock at all times.

### 14.1 Service Locations

For additional assistance, questions or technical support, please contact:

Tisch Environmental  
 145 South Miami Ave.  
 Cleves, OH 45002  
 513.467.9000  
 sales@tisch-env.com

Visit us on the web for product updates at [www.tisch-env.com](http://www.tisch-env.com).

### 14.2 Electrical System

The electrical system is rated for 120/230VAC at 50/60Hz. The system is transitioned to 24VDC using a 60 watt power supply which in turn powers the system. AC Mains power is switched through the front green LED pushbutton switch. AC power is interrupted from a 1A pushbutton circuit breaker and DC power is interrupted from a 3A fuse.

Condition	Possible Cause	Possible Remedy
Unit will not power on	No AC Mains power	Using a voltage meter, check power on the cord and ensure cord is seated properly in the socket in the side box.

Condition	Possible Cause	Possible Remedy
<p>Sampler states ‘mains power off’ but unit is plugged into mains source</p>	<p>No DC power</p>	<p>Open front cover, if green LED is not ON check voltage on black connector, if voltage is present, check operation of the pushbutton and ensure voltage to the purple connector when button is pressed, replace green LED pushbutton if not functioning properly.</p> <p>If voltage is not present on the black connector and mains power is plugged in, then check the 1A circuit breaker for proper operation.</p> <p>Check DC operation – ensure AC mains power is present on L and N on the top of the power supply and DC(+) and DC(-) has 27VDC present. If DC power is present and the unit will not power on, check and replace the 3A fuse.</p> <p>If there is AC voltage present on the power supply and no DC voltage from the power supply, disconnect the DC(+) terminal and measure again. If still no voltage replace power supply.</p> <p>If after disconnecting the DC(+) wire and there is 27VDC on the DC(-) and DC(+) terminals, there is a short somewhere between the DC(+) and DC(-) terminals.</p>
	<p>Power fail relay needs replaced</p>	<p>Ensure mains power is on and by following steps above. There is a green LED on the front of the relay that indicates the unit is powered. Check to ensure there is AC voltage on terminals A1 and A2 on the power fail relay.</p> <p>Check continuity on terminals 11 and 12. When power is off, these terminals should be closed and when power is on the terminals should be open.</p> <p>If power fail relay is operating properly, check the input to the PLC. The power fail relay is connected to input 3. When mains power is off the LED on the PLC for input 3 should be ON.</p>

Condition	Possible Cause	Possible Remedy
UPS does not switch to battery during a power failure	UPS defective	<p>Check voltage on DC(+) and DC(-) terminals on UPS, should be 27VDC. Check the battery (+) and (-) terminals, these should also be 27VDC.</p> <p>Disconnect battery pack and measure voltage from the battery pack. This should be 24VDC.</p> <p>Replace UPS.</p>
System does not stay powered during loss of mains power	Battery pack needs replaced	<p>Turn off mains power and measure the voltage on the Battery (+) and (-) terminals. This should be 24VDC. Ensure the battery pack is fully charged by leaving it plugged in for 24 hours.</p> <p>Ensure when mains power is on that the voltage on the Battery (+) and (-) terminals is 27VDC, this is necessary to properly charge the batteries.</p> <p>Replace battery pack.</p>

### 14.3 Touchscreen Troubleshooting

The touchscreen is TE-Wilbur part number TE-W-100. The touchscreen is powered from the DC power supply and connects to the PLC via a communication cable. The screen has an internal SD card that is located on the left side when looking at the rear of the screen.

Condition	Possible Cause	Possible Remedy
No display	No DC power to screen	<p>Check voltage on connector to the screen. Should be 27VDC.</p> <p>Check green LED on front of screen, should be ON when voltage is present.</p> <p>Replace screen.</p>
Message stating battery	Internal battery	Replace internal battery.

low	needs replaced	
<b>Condition</b>	<b>Possible Cause</b>	<b>Possible Remedy</b>
Message stating Host communication lost	Communication to PLC has stopped	<p>Check cable from the screen to the PLC and ensure it did not become unseated on both ends.</p> <p>Check to ensure the PLC is in run mode by observing the LED on the PLC.</p> <p>Update firmware of both screen and PLC.</p> <p>Replace screen and or PLC.</p>
USB does not function	USB stick not working	<p>Try a different make and model of USB stick.</p> <p>Check to ensure the USB interconnect cable is plugged into the screen and is seated into the socket.</p> <p>Update firmware of screen.</p> <p>Remove DC power from screen (reboot screen) by unplugging the screen power connector.</p> <p>Replace screen.</p>
Graphics are missing on screen and logs are not working	SD Card is not functioning	<p>The SD card is located on the left side as you are looking at the rear of the touchscreen. Ensure the SD card is seated properly by pushing in and pulling out.</p> <p>Replace SD card.</p> <p>Update firmware.</p> <p>Replace screen.</p>

## 14.4 Flowmeter

The flowmeter is a TE-Wilbur part number TE-W-150. The flowmeter is a thermal mass type that is ranged 0-25 Lpm and provides a 4/20mA analog output to the PLC for flow indication. The flowmeter is powered from the DC power supply.

Condition	Possible Cause	Possible Remedy
No flow when pump is running or alarm that flowmeter is failed	Cable unplugged	Check the cable that connects to the flowmeter and ensure it is seated properly.
	Flowmeter failed	<p>There is an indicator light on the top of the flowmeter that will blink green when flow is present and red when a failure occurs.</p> <p>Check that there is 27VDC on terminals 5(+) and 6(-) which is the power for the flowmeter.</p> <p>Remove the wire from terminal 4 (signal) and place a current meter that can measure mA signals in series from the wire to the terminal. When flow is traveling through the flowmeter there should be a proportional 4-20mA signal through this signal wire.</p> <p>If 4-20mA signal is present and working, then replace the analog card on the PLC.</p> <p>Replace flowmeter.</p>
	No flow	<p>Check all pneumatic connections to the flowmeter to ensure there is air flow through the flowmeter sensor.</p> <p>Replace flowmeter.</p>

## 14.5 Barometric Pressure

The barometric pressure sensor is a TE-Wilbur part number TE-W-154. The barometric pressure sensor is a highly accurate sensor that is powered from the DC power supply and provides a 4/20mA signal proportional to the range of the barometric pressure. The range of the sensor is 450 to 1238 mmHg.

Condition	Possible Cause	Possible Remedy
Wrong or no reading of barometric pressure or alarm that sensor has failed	Sensor unplugged	Check the cable that connects to the barometric pressure sensor and ensure it is connected properly onto the terminal strip at the following terminal locations:  White wire (signal) – Terminal 9 Black wire (Ground) – Terminal 10 Red wire (Supply) – Terminal 11
	No Voltage	Check to make sure there is 27VDC on terminals 11(+) and 10(-).
	Sensor or PLC input card failed	Remove the wire from terminal 9 (signal) and place a current meter that can measure mA signals in series from the wire to the terminal. At standard barometric pressure of 760mmHg the sensor should be outputting around 5mA.  If 4-20mA signal is present and working, then replace the analog card on the PLC.  Replace Barometric pressure sensor.

## 14.6 Temperature Sensors

The ambient temperature probe, part number TE-W-151, and the filter temperature probe, part number TE-W-152, are both the same types of probes so troubleshooting steps apply to both the ambient and filter temperatures. The probes are PT100 RTDs (Resistive Temperature Devices). When at 0°C the resistance of the probe will be 100Ω and as temperature increases and decreases, the resistance of the probe will increase and decrease respectively. The probes are highly accurate when used for measuring ambient conditions and are very linear throughout their temperature range.

Condition	Possible Cause	Possible Remedy
No reading or alarm that sensor is unplugged or failed	Sensor unplugged	Ensure the connector for the probe is seated properly.
	Sensor failed	Measure the resistance on terminals 13 and 14 for the ambient temperature and 15 and 16 for the filter temperature. See the PT100 lookup table to verify the correct resistance versus temperature.

### °C Resistance of PT100 Temperature Sensor

-40	84.27	83.87	83.48	83.08	82.69	82.29	81.89	81.50	81.10	80.70	80.31	-40
-30	88.22	87.83	87.43	87.04	86.64	86.25	85.85	85.46	85.06	84.67	84.27	-30
-20	92.16	91.77	91.37	90.98	90.59	90.19	89.80	89.40	89.01	88.62	88.22	-20
-10	96.09	95.69	95.30	94.91	94.52	94.12	93.73	93.34	92.95	92.55	92.16	-10
0	100.00	99.61	99.22	98.83	98.44	98.04	97.65	97.26	96.87	96.48	96.09	0
10	103.90	104.29	104.68	105.07	105.46	105.85	106.24	106.63	107.02	107.40	107.79	10
20	107.79	108.18	108.57	108.96	109.35	109.73	110.12	110.51	110.90	111.29	111.67	20
30	111.67	112.06	112.45	112.83	113.22	113.61	114.00	114.38	114.77	115.15	115.54	30
40	115.54	115.93	116.31	116.70	117.08	117.47	117.86	118.24	118.63	119.01	119.40	40

Condition	Possible Cause	Possible Remedy
	Sensor failed	<p>If resistance does not match within 10% replace the sensor.</p> <p>If resistance is correct, but the temperature is still not reading correctly or there is still an alarm for sensor unplugged or failed, replace the PLC analog input/output card.</p>

## 14.7 Pump system

The pump is a TE-Wilbur part number TE-W-300 with the TE-W-301 pump controller circuit board. The pump is a brushless 24VDC motor with a diaphragm-type pump. The pump is controlled via a pump controller circuit board located inside on the back panel. The pump controller takes a voltage input from the PLC output card that is ranged 1-5 VDC from zero speed to full speed. The pump controller board is also powered from the 24VDC supply.

Condition	Possible Cause	Possible Remedy
Pump will not start	<p>Cable unplugged</p> <p>Controller board pump or analog output card failed</p>	<p>Ensure all the connectors on the pump controller are seated properly.</p> <p>Measure voltage on the 24VDC terminals, should be 27VDC. See Section 12 for diagram of the controller board.</p> <p>Put the pump in manual by selecting on the screen &lt;Maintenance&gt; &lt;Manual Control&gt; and select to run the pump in manual control. Ramp up the pump speed to about 50%. Measure the voltage on the control signal connector – it should be a 2-3VDC. If no voltage is present when in manual mode check all wiring to the PLC card. Replace the PLC analog output card.</p> <p>Make sure the pump cable is seated properly and is in the terminal correctly. Remove and seat again. Try replacing the pump if all signals to the board are working.</p> <p>Replace the controller board if you have 27VDC on the power connection and the PLC is giving a correct output control signal and you have replaced the pump.</p>



## 14.8 Pressure Sensor

The vacuum pressure sensor is a TE-Wilbur part number TE-W-153. The vacuum pressure sensor used in the TE-Wilbur sampler is ranged 0-15psia vacuum and provides a 4/20mA signal based on vacuum pressure.

Condition	Possible Cause	Possible Remedy
Pressure sensor alarm, cable unplugged or failed	<p>Cable unplugged</p> <p>Sensor failed</p> <p>PLC input card failed</p>	<p>Ensure the connector for the pressure sensor is plugged in and seated properly.</p> <p>Ensure there is 27VDC on terminal 7 to DC ground which is the pressure sensor supply voltage.</p> <p>Using an amp-meter capable of measuring mA disconnect the wire on terminal 8 and place one probe on terminal 8 and one probe on the wire from the pressure sensor you just removed. At no pressure you should have a pressure reading between 4-5mA. If you have no mA reading, replace the pressure sensor.</p> <p>If you have a 4-5mA reading with no pressure you can pressurize the sensor by running the pump in manual mode and restricting the flow. As you restrict the flow you should see the mA output climb. If the mA output is working and the alarm still exists or it is still not reading correctly, replace the analog input card.</p>

## 14.9 Solenoid

The solenoid is a TE-Wilbur part number TE-W-212.

Condition	Possible Cause	Possible Remedy
Solenoid does not activate during leak check	Ensure pressure is working properly	The solenoid will turn on (Close) when the system pressure exceeds 50" H <sub>2</sub> O during a leak check.
	Solenoid failed	Take a jumper wire and place one end on 24VDC and the other end on terminal 3. The solenoid should come on and you should hear a 'click' from the valve closing.  If the solenoid does not come on check the wiring. Replace solenoid.
	PLC failed	If solenoid does come on when placing the jumper on terminal 3, check the wiring to the PLC card (outputs right side). When solenoid is supposed to be ON from a leak check being performed and the pressure being greater than 50" the LED for output 4 should be on. Replace PLC card.

## 14.10 Exhaust Fan

The exhaust fan is a TE-Wilbur part number TE-W-203

Condition	Possible Cause	Possible Remedy
Exhaust fan does not come on when temperature variance is 3 Deg C	Temperature sensor failed	The fan will come on and run for 30 seconds when the temperature variance between ambient and the filter temperature exceeds 3 Deg C. Calibrate the ambient temperature to a false value to achieve a temperature variance of more than 3 degrees to check fan operation.
	Fan failed	Take a jumper wire and place one end on 24VDC and the other end on terminal 2. The fan should come on. Check for 27VDC on the connector to the fan.  If the fan does not come on check the wiring. Replace fan.



## 15.0 Communications

This section outlines the communication options, configuration and operation available with the TE-Wilbur sampler.

### 15.1 Introduction

The TE-Wilbur has a built-in RJ-45 Ethernet connection that allows for remote access of the system, a web browser interface and the ability to download data remotely. Also, the TE-Wilbur sampler has a Modbus slave port that allows connection to a telemetry system for remote data logging and viewing and connection to the Tisch Environmental FRM-CAL Calibrator.

### 15.2 Ethernet Connection

The TE-Wilbur sampler has a standard RJ-45 Ethernet connection that is located in the weatherproof box on the side. This connection is routed through to the touchscreen where the connection is made.

If connection of the sampler is made to a switch, then a standard RJ45 CAT5/6 patch cable can be used.

If connecting this port directly to a PC an RJ45 CAT5/6 crossover cable must be used.

The system is set for a default IP address as follows:

IP Address 192.168.1.123  
Subnet Mask 255.255.255.0  
No gateway is set

In order to connect to the sampler via the Ethernet port your PC must also be set to the same subnet, for example:

IP Address 192.168.1.124 (notice the IPs cannot be the same)  
Subnet Mask 255.255.255.0

In this example the subnet is '192.168.1' and any addresses from 1 to 255 can be used except the '.123' that is being used by the sampler.

To change the IP address / Subnet of the sampler perform the following steps:

Press and hold the top right corner of the touchscreen to enter Maintenance mode and the following screen will appear:

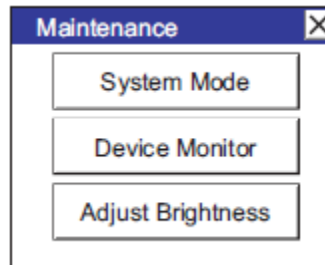

Press system mode to enter the internal setup of the touch screen and the following screen will appear. Press Offline.

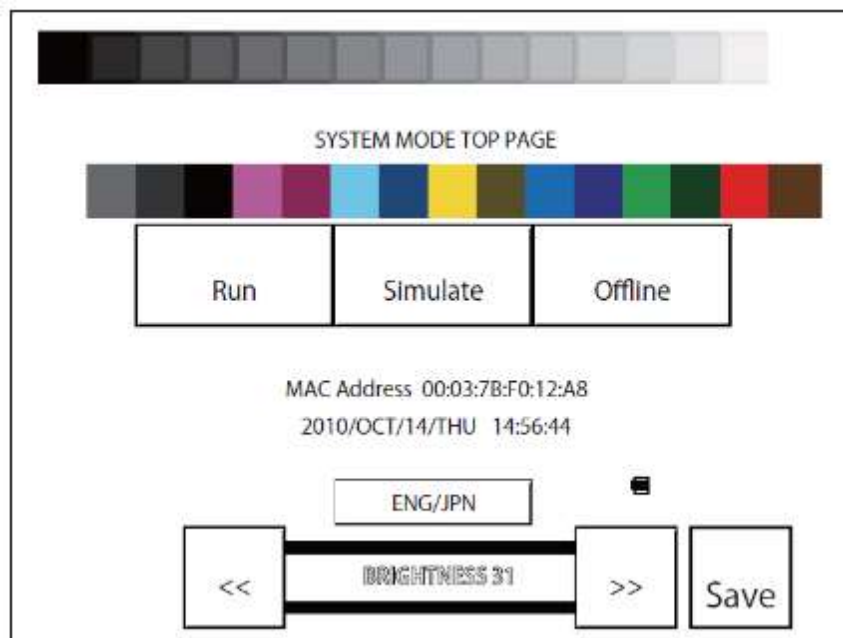

**NOTE:** Care must be taken when entering the Maintenance Mode of the touch screen. Failure could result if the wrong keys are pressed.

Now press the following menu buttons:



Use the keypad to enter the desired IP address and subnet mask. Press the enter button to apply the entered values.

Press Exit to return, then at the Main Menu, press the RUN button to start the system and return to the sampler’s operation screens.

### 15.3 Webservice Functions

To access the webservice functions, the sampler must be hooked up to a network and configured for the correct subnet.

Using a standard browser that supports frames (IE 8.0 and higher is recommended or Google chrome) open a new browser window and type the following in the address bar:

`http://192.168.1.123/`

Where 192.168.1.123 is the touchscreen’s IP address, if this address has changed, then you must type the new address in the address bar.

A security window will appear to enter a username and password:

**Username:** Wilbur  
**Password:** *blank*

The user name is ‘Wilbur’ which is case sensitive so the capital ‘W’ must be used in the username field.

Leave the password field empty, there is no password.

The following screen will appear:

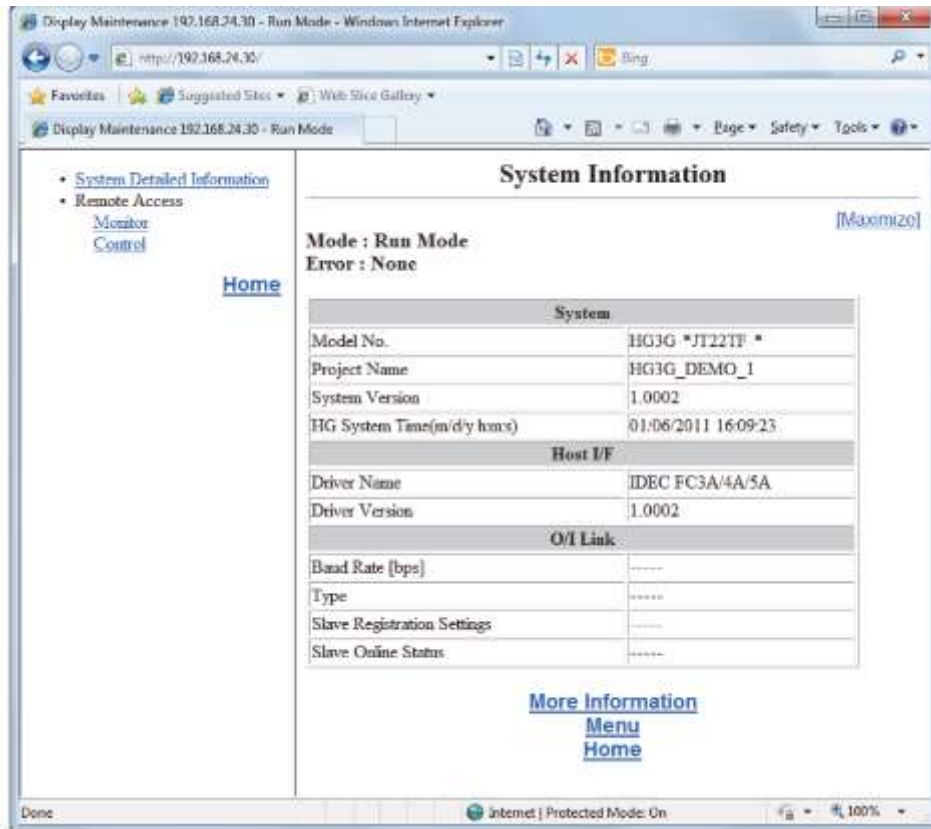

On the left window pane the following options are available:

- Monitor Will show the same screen the touchscreen is showing. Does not allow for remote control, just monitoring only.
- Control Will allow the touchscreen to be controlled from the web browser window.

## 15.4 Remote Data Upload

The TE-Wilbur sampler allows for remote uploading of the data log and history log using a software tool called Downloader which is produced and supported by IDEC Corporation.

The downloader tool can be found and downloaded at this address:

[http://www.idec.com/caen/products/Catalogs/Software/WindOI\\_NV2/document.html](http://www.idec.com/caen/products/Catalogs/Software/WindOI_NV2/document.html)



**NOTE:** The downloader tool can cause unrecoverable loss of data and can render the system disabled if the wrong functions are performed.

After installation of the downloader tool, click on the icon and launch the program.

Click on Options and select ‘Communication Settings...’

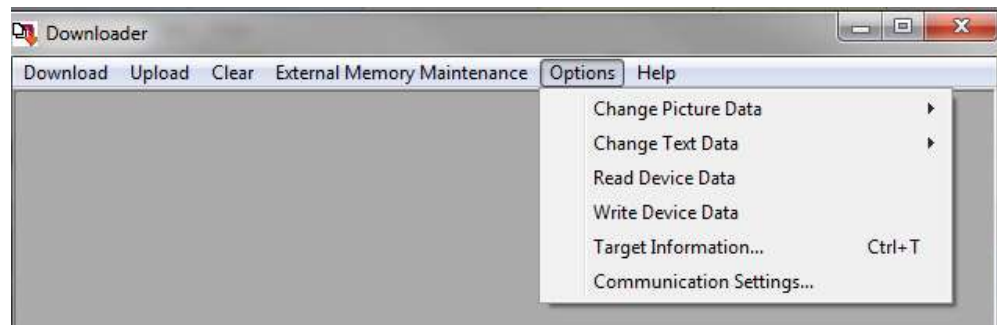



The following window will open. Select to communicate with a MICRO/I and set the port to Ethernet.

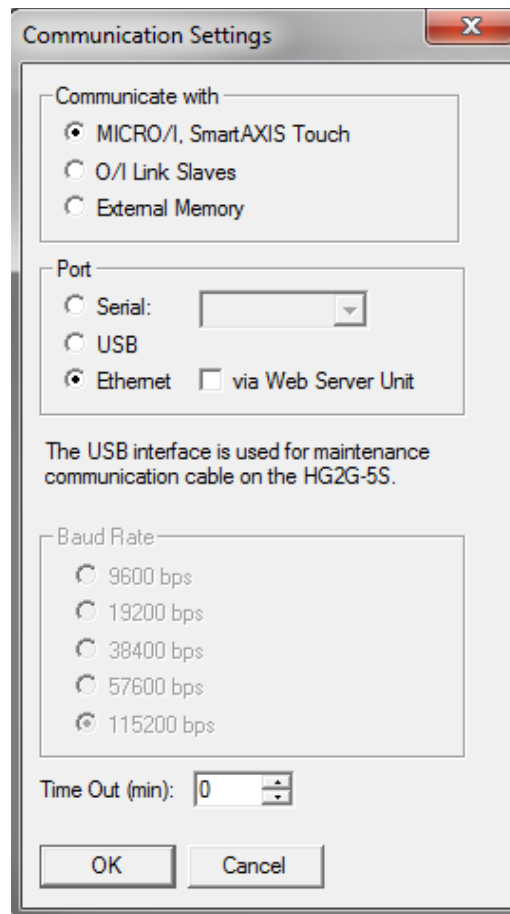

To upload the data log or history log to your PC perform the following:

Click on Upload

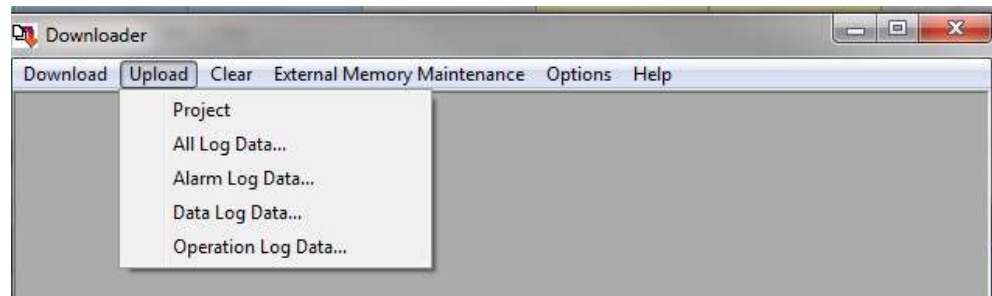

Then click:

- All Log Data            To download all logs
- Data Log Data        To download the data log or run summary log
- Alarm Log Data        To download the history log

The software will then ask for a path to save the data, select a path and click OK to save the file.

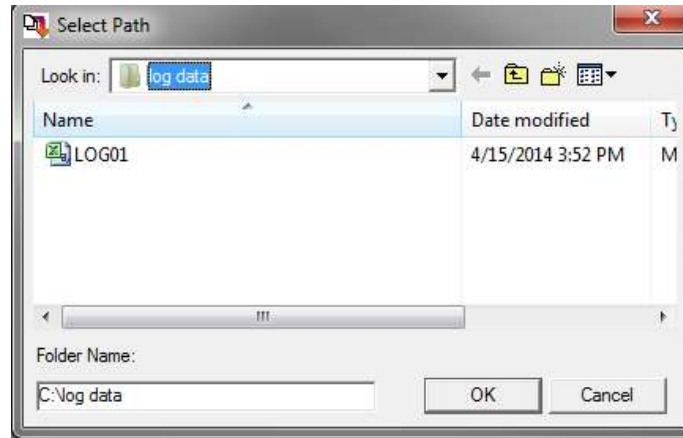

## 15.5 MODBUS Configuration

The TE-Wilbur MODBUS port is located on the side box and is configured as an RS485 RJ-11 plug. The communication parameters for MODBUS are configured as follows:

Modbus Serial Protocol – RS485 SLAVE

Baud Rate (bps)	9600
Data Bits	8
Parity	Even
Stop Bits	1
Slave Number	1 (default)

The cable needed for connection to the Modbus is a Tisch Environmental part number TE-W-217 and has the following RS-485 pin connections:

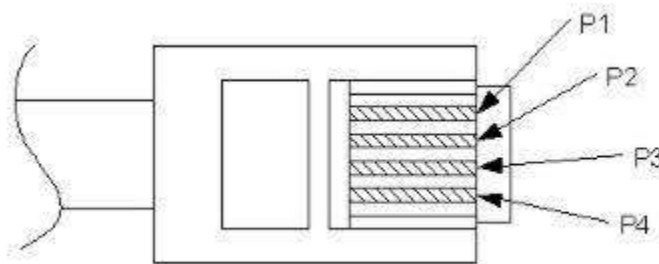

- P1 A(+)
- P2 Not Used
- P3 Not Used
- P4 B(-)

The Slave address of the sampler can be set by following these keystrokes:



Change MODBUS Screen

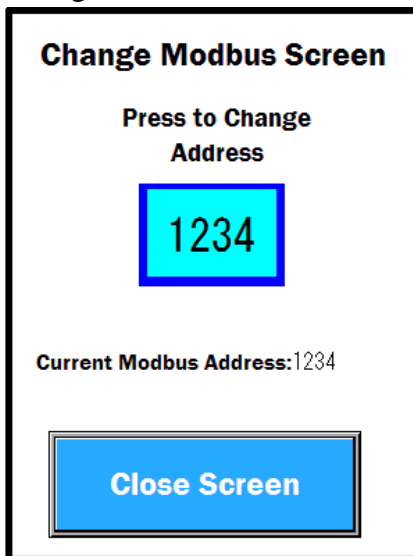

The MODBUS valid addresses are 1 thru 1000

## 15.6 MODBUS Data Map

The following MODBUS Data registers are used:

<b>MODBUS Address</b>	<b>Comm Frame</b>	<b>Data Type</b>	<b>TE-Wilbur Internal Address</b>	<b>Description</b>
413001	32C8	Float32	D13000	30 second Average Volumetric Flow
413003	32CA	Float32	D13002	30 second Max Volumetric Flow
413005	32CC	Float32	D13004	30 second Min Volumetric Flow
413007	32CE	Float32	D13006	30 second Average Baro Pressure
413009	32D0	Float32	D13008	30 second Max Baro Pressure
413011	32D2	Float32	D13010	30 second Min Baro Pressure
413013	32D4	Float32	D13012	30 second Average Filter Temp
413015	32D6	Float32	D13014	30 second Max Filter Temp
413017	32D8	Float32	D13016	30 second Min Filter Temp
413019	32DA	Float32	D13018	30 second Average Ambient Temperature
413021	32DC	Float32	D13020	30 second Max Ambient Temperature
413023	32DE	Float32	D13022	30 second Min Ambient Temperature
413025	32E0	Float32	D13024	30 second Average System Pressure
413027	32E2	Float32	D13026	30 second Max System Pressure
413029	32E4	Float32	D13028	30 second Min System Pressure
413031	32E6	Float32	D13030	Data Log Average Volumetric Flow
413033	32E8	Float32	D13032	Data Log Max Volumetric Flow
413035	32EA	Float32	D13034	Data Log Min Volumetric Flow
413037	32EC	Float32	D13036	Data Log Average Baro Pressure
413039	32EE	Float32	D13038	Data Log Max Baro Pressure
413041	32F0	Float32	D13040	Data Log Min Baro Pressure
413043	32F2	Float32	D13042	Data Log Average Filter Temp
413045	32F4	Float32	D13044	Data Log Max Filter Temp
413047	32F6	Float32	D13046	Data Log Min Filter Temp
413049	32F8	Float32	D13048	Data Log Average Ambient Temperature
413051	32FA	Float32	D13050	Data Log Max Ambient Temperature
413053	32FC	Float32	D13052	Data Log Min Ambient Temperature
413055	32FE	Float32	D13054	Data Log Average System Pressure
413057	3300	Float32	D13056	Data Log Max System Pressure
413059	3302	Float32	D13058	Data Log Min System Pressure
413061	3304	Float32	D13060	Data Log Average Temp Variance
413063	3306	Float32	D13062	Data Log Max Temp Variance
413065	3308	Float32	D13064	Data Log Min Temp Variance
413067	330A	Float32	D13066	Flow total

<b>MODBUS Address</b>	<b>Comm Frame</b>	<b>Data Type</b>	<b>TE-Wilbur Internal Address</b>	<b>Description</b>
413069	330C	Float32	D13068	Flow CV
413071	330E	Float32	D13070	Sample Time
413073	3310	BIN32	D13072	Filter ID
413075	3312	BIN32	D13074	Site ID
413077	3314	BIN32	D13076	Serial Number
413079	3316	Float32	D13078	Instantaneous Flow Reading
413081	3318	Float32	D13080	Instantaneous Baro Pressure Reading
413083	331A	Float32	D13082	Instantaneous Filter Temp Reading
413085	331C	Float32	D13084	Instantaneous Ambient Temp Reading
413087	331E	Float32	D13086	Instantaneous System Pressure Reading
002604	0A2B	Binary	M2003	10% Flow Variance Alarm
002606	0A2D	Binary	M2005	High Pressure Alarm
002616	0A37	Binary	M2017	5% Flow Variance Alarm
002617	0A37	Binary	M2020	Sample time <23 or >25 hours
002612	0A33	Binary	M2013	Ambient Temperature Failure
002613	0A343	Binary	M2014	Filter Temperature Failure
002609	0A30	Binary	M2010	Flowmeter Failure
002611	0A32	Binary	M2012	Barometric Pressure Failure
002610	0A31	Binary	M2011	Pressure Sensor Failure
002627	0A42	Binary	M2032	Temperature Variance Alarm
002628	0A43	Binary	M2033	Sample Warning Alarm
002630	0A45	Binary	M2035	Battery Discharge Alarm
002631	0A46	Binary	M2036	Battery Failure Alarm
001512	05E7	Binary	M0637	Shut Down Sample Alarm
001529	05F8	Binary	M0660	Screen Battery Failure
001652	0673	Binary	M0813	Power Fail
001772	06EB	Binary	M0963	Mains Power Lost
001497	05D8	Binary	M0620	Custom Sample Set
001501	05DC	Binary	M0624	1 in 3 Sample Set
001502	05DD	Binary	M0625	1 in 6 Sample Set
001503	05DE	Binary	M0626	1 in 12 Sample Set
001500	05DB	Binary	M0623	Sample Running

## Appendix A: Parts List

Appendix A is a complete parts listing of the TE-Wilbur sampler, accessories and optional equipment.

### A.1 Parts List

The TE-Wilbur can be ordered with (3) configurations for the collection of particulate matter.

TE-Wilbur10	Includes the TE-PM10 10µm collection head.
TE-Wilbur2.5	Includes the TE-PM10 10µm collection head and the TE-PM2.5C PM <sub>2.5</sub> cyclone fractionator.
TE-WilburTSP	Includes the TE-TSP collection head.
TE-FRM-CAL	Advanced automatic calibrator for the TE-Wilbur air sampling platform

Part Number	Description
TE-PM-10	PM <sub>10</sub> 10µ collection head
TE-PM2.5C	PM <sub>2.5</sub> cyclone fractionator
TE-W-STAND	TE-Wilbur stand (complete)
TE-FH	TE-Wilbur Filter Holder (complete)
TE-FH47	Filter cassette top, bottom with screen
TE-W-001	Inlet downtube
TE-W-002	Downtube adapter (black delrin) w/ o-rings
TE-W-003	Silicone gasket for downtube adapter
TE-W-004	Internal leak check disk (solid black disk)
TE-W-005	TE-Wilbur instruction manual
TE-W-050	TE-Wilbur enclosure (complete)
TE-W-051	Left internal side plate with opening
TE-W-052	Left back mounting plate
TE-W-053	Battery case
TE-W-054	Side box connection internal plate

<b>Part Number</b>	<b>Description</b>
TE-W-055	Filter holder mounting plate
TE-W-056	Pump mounting plate
TE-W-057	Left touch screen panel
TE-W-058	Left, bottom plate
TE-W-059L	LED strip 10" long with wires
TE-W-059R	LED strip 8" long with wires
TE-W-060	(4) Rubber feet
TE-W-061	Black Polycarbonate Handle
TE-W-100	Main color touchscreen
TE-W-101	Main controller module
TE-W-102	Analog input card
TE-W-103	Analog input / output card
TE-W-104	Modbus communication module
TE-W-105	Screen to controller communication cable
TE-W-106	32M SD Card for touchscreen
TE-W-107	USB stick for touchscreen
TE-W-150	Thermal mass flowmeter 0-25 Lpm range
TE-W-151	Ambient temperature RTD with radiation shield
TE-W-152	Filter temperature RTD
TE-W-153	Vacuum pressure sensor
TE-W-154	Barometric pressure sensor
TE-W-200	TE-Wilbur 24VDC Battery Pack
TE-W-201	UPS Module
TE-W-202	24VDC 60 watt power supply
TE-W-203	24VDC Enclosure fan
TE-W-204	Fan guard
TE-W-205	Enclosure louvers
TE-W-206	Power button with green LED

<b>Part Number</b>	<b>Description</b>
TE-W-207	USB interconnection cable
TE-W-208	24VDC Main fuse
TE-W-209	Power cord with US end to IEC320 connection
TE-W-210	AC inlet socket
TE-W-211	Ethernet connector for side box
TE-W-212	24VDC Solenoid
TE-W-213	Side box for external connections
TE-W-214	Power fail relay
TE-W-215	3.3V Lithium Ion battery for screen
TE-W-216	Ethernet patch cable
TE-W-217	Modbus connector for side box
TE-W-223	1Amp Mains Pushbutton Circuit Breaker
TE-W-300	Brushless 24VDC pump
TE-W-301	Pump control circuit board
TE-W-302	Cable for pump control board
TE-W-303	Pump rebuild kit
TE-W-304	Pump muffler 1/8" NPT
TE-W-F01	Pump suction fitting – pushfit 3/8 tube
TE-W-F02	Solenoid to pump connection pushfit 3/8 tube
TE-W-F03	Solenoid fitting to flowmeter 1/4 compression
TE-W-F04	Flowmeter fittings 1/4 compression
TE-W-F05	Pressure sensor tee
TE-W-F06	1/4 OD polyurethane tubing
TE-W-F07	3/8 OD PUR tubing



## A.2 Filter Holder Parts List

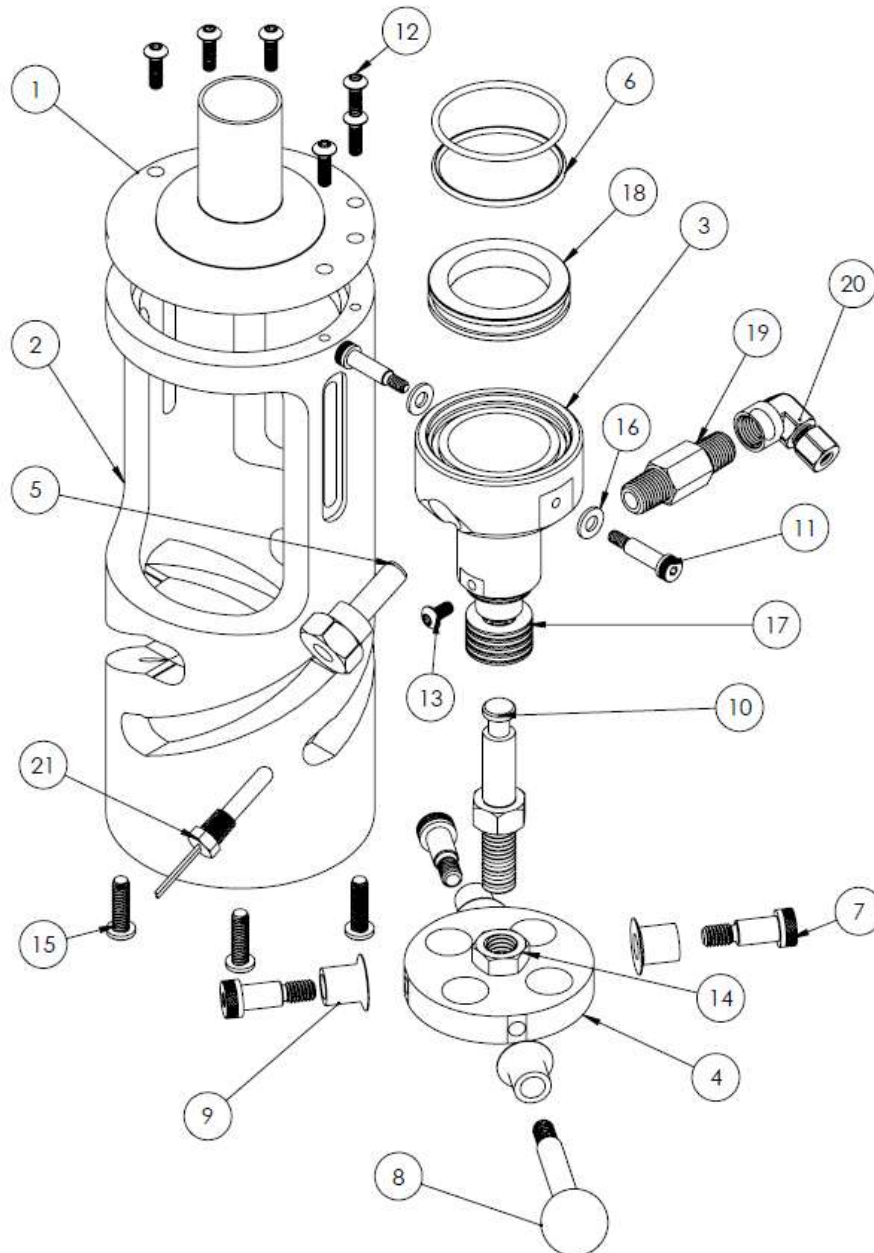

<b>Number</b>	<b>Part Number</b>	<b>Description</b>
1	TE-W-FH1	Top mate
2	TE-W-FH2	Helix Lever Base
3	TE-W-FH3	Bottom mate
4	TE-W-FH4	Cam lever plate
5	TE-W-FH5	Thermowell
6	TE-W-FH6	Bottom and top mate o-rings (Qty 2)
7	TE-W-FH7	5/16-18 shoulder bolt (Qty 3)
8	TE-W-FH8	Lever handle with ball (stainless steel)
9	TE-W-FH9	Cam bushing (Qty 4)
10	TE-W-FH10	Drive rod
11	TE-W-FH11	10-24 shoulder bolt (Qty 2)
12	TE-W-FH12	10-32 socket cap screw (Qty 6)
13	TE-W-FH13	Set screw
14	TE-W-FH14	Drive rod nut
15	TE-W-FH15	1/4-20 mounting bolts (Qty 4)
16	TE-W-FH16	PTFE washer (Qty 2)
17	TE-W-FH17	Belleville washers (Qty 10)
18	TE-FH47	Filter Cassette
19	TE-W-FH19	Filter holder hex nipple
20	TE-W-FH20	Compression fitting elbow
21	TE-W-152	PT100 RTD Filter Holder Temperature Probe

### A.3 Optional Accessories

Part Number	Description
TE-W-500	Filter Cassette Separator tool
TE-W-501	Modbus cable – RJ9 2-wire 25’ long
TE-W-502	External 24VDC connection cable 25’ long
TE-W-503	Ethernet cable RJ45 25’ long

### A.4 Solar Option Parts List

Part Number	Description
TE-W-600	Solar control system panel complete w/o Batteries
TE-W-601	Solar controller
TE-W-602	250 watt 24VDC Solar panel
TE-W-603	MC cables 10’ long
TE-W-606	Solar Mounting Kit
TE-W-608	External connection cable 25’ long

### A.5 O-Ring Replacement Part Numbers

PM<sub>10</sub> Head replacement o-rings P/N: TE-W-020 for complete kit

Quantity	Description	Part Number
2	Exit Adapter O-Rings	TE-W-022
1	Impactor Nozzle O-Ring	TE-W-023
2	Downtube O-Rings	TE-W-021

TE-PM<sub>2.5C</sub> replacement o-rings P/N: TE-W-030 for complete kit

Quantity	Description	Part Number
2	Exit Nozzle O-Rings	TE-W-031
1	Collector Cup O-Ring	TE-W-032
1	Threaded Insert O-Ring	TE-W-033
4	Connector tube O-Rings	TE-W-034
2	Stainless bolt O-Rings	TE-W-035

## Appendix B: Drawings

Appendix B includes detailed drawings on the TE-Wilbur sampler.

### B.1 Electrical Terminal TB1 connections

Terminal Number	Description
1	(+) terminal for LED lighting strips Blue/Green wire
2	(+) terminal for ventilation fan Brown wire
3	(+) terminal for solenoid valve
4	black wire – (+) signal output from flowmeter
5	brown wire – (+) supply voltage to flowmeter
6	blue wire – (-) supply voltage to flowmeter
7	(+) Supply and signal to pressure sensor
8	(-) supply and signal to pressure sensor
9	white wire – (+) signal from barometric pressure sensor
10	black wire – (-) supply to barometric pressure sensor
11	red wire – (+) supply to barometric pressure sensor
12	(+) signal for pump speed control
13	(-) signal for pump speed control
14	ambient temperature connection (no polarity)
15	ambient temperature connection (no polarity)
16	filter temperature connection (no polarity)
17	filter temperature connection (no polarity)
18	(+) connection for battery pack
19	(-) connection for battery pack

## B.2 TE-Wilbur Drawings

Illustration of sampler with enclosure shut



Illustration of sampler setup for PM<sub>10</sub> collection

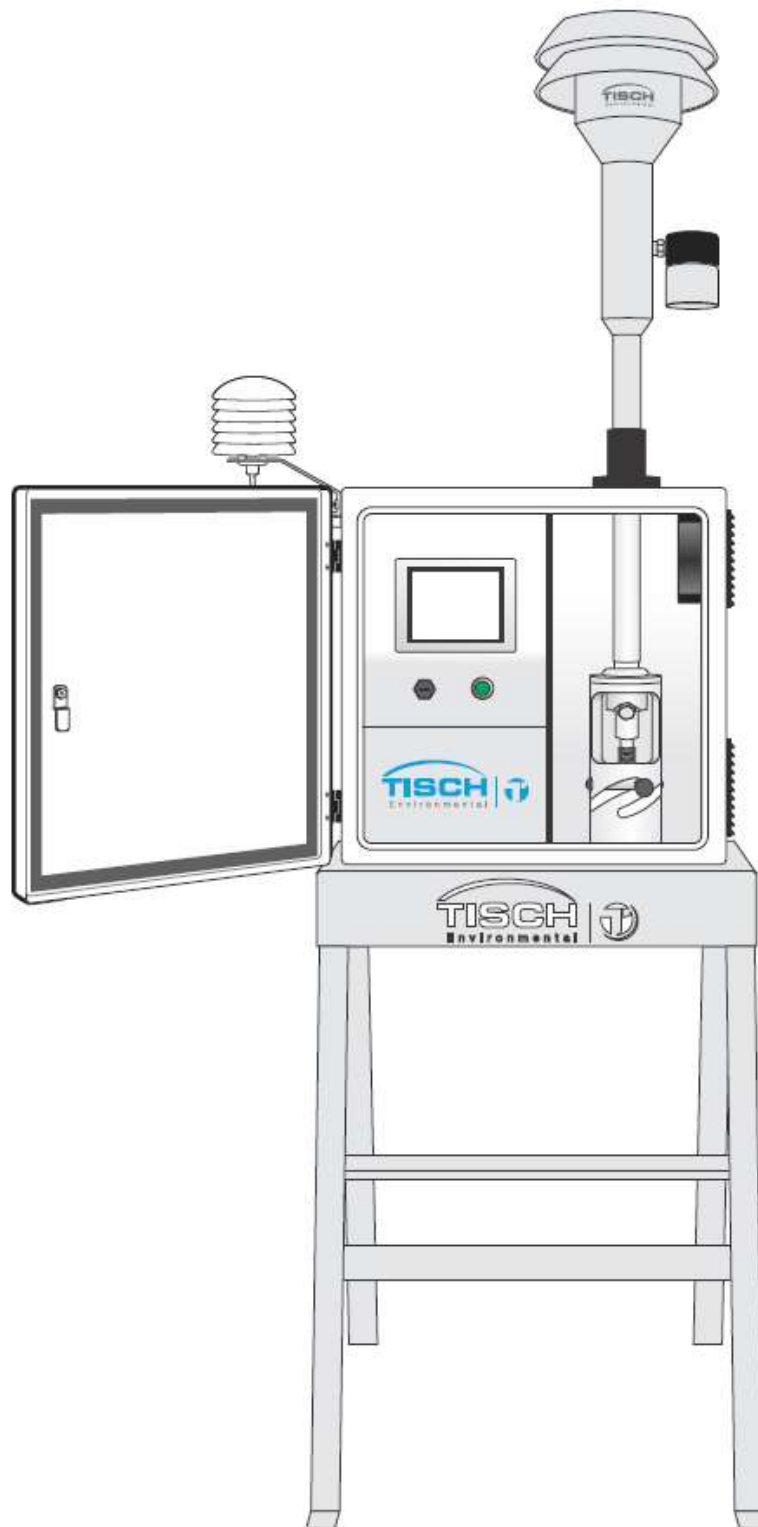
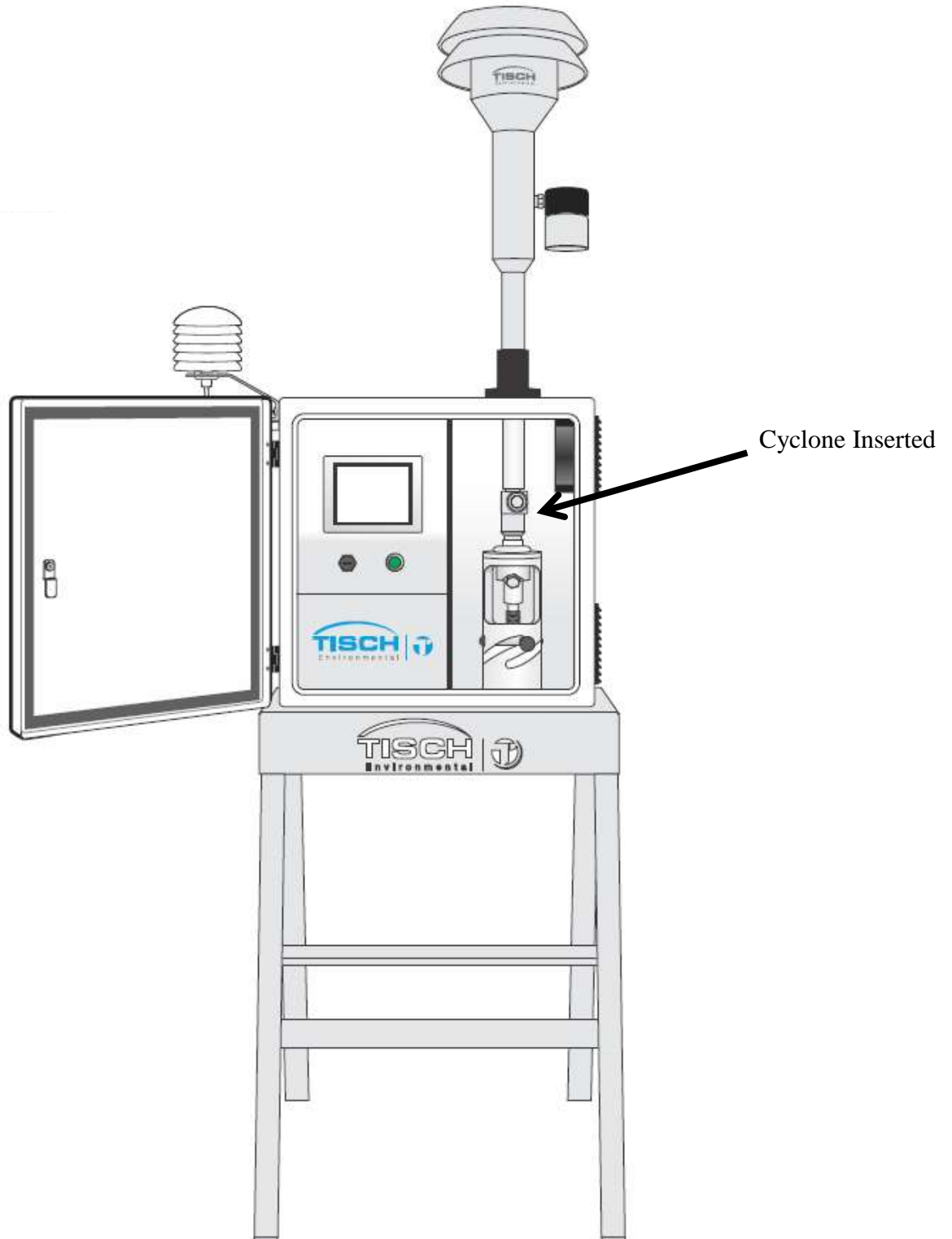

Illustration showing sampler setup for PM<sub>2.5</sub> collection



### B.3 Enclosure Stand Drawing

ITEM NO.	PART NUMBER	QTY.
1	TischHolderStand041214	1
2	TischHolderStandBoxMountAngles	2
3	1/4-20 Nut Inserts	8
4	TischHolderStandlegAssembly	2
5	1/4-20 X 1 Screw	16
6	1/4-20 Nylon Nut	4
7	# 10-32 X 1/2 Screw	8
8	#10-32 Nylon Nut	8

<p><b>PROPRIETARY AND CONFIDENTIAL</b>                  THE INFORMATION CONTAINED IN THIS DRAWING IS THE SOLE PROPERTY OF TISCH ENVIRONMENTAL. ANY REPRODUCTION IN PART OR AS A WHOLE WITHOUT THE WRITTEN PERMISSION OF TISCH ENVIRONMENTAL IS PROHIBITED.</p>		<p>REVISIONS:</p> <table border="1"> <tr> <th>REV</th> <th>DESCRIPTION</th> </tr> <tr> <td>C</td> <td>Bolt Config</td> </tr> <tr> <td>B</td> <td>Bolt sizes</td> </tr> </table>		REV	DESCRIPTION	C	Bolt Config	B	Bolt sizes
REV	DESCRIPTION								
C	Bolt Config								
B	Bolt sizes								
<p>APPLICATION: Change</p>		<p>DATE: 9-15-14</p>							
<p>DO NOT SCALE DRAWING</p>		<p>SCALE: 1/8" = 1"</p>							
<p>MATERIAL: ALUMINUM per Tisch</p>		<p>WEIGHT: 15.0 LBS</p>							
<p>TOLERANCES ARE IN INCHES</p>		<p>STAND ASSEMBLY</p>							
<p>FINISH: --</p>		<p>TISCH</p>							
<p>FRAC TIONAL: 1/16, 1/8, 1/4, 1/2, 3/4</p>		<p>DESIGNER: DS</p>							
<p>ANGULAR: MACH: 1 BELD: 1</p>		<p>CHECKED: [ ]</p>							
<p>TWO PLACE DECIMAL: ±.010</p>		<p>ENG APPR: [ ]</p>							
<p>THREE PLACE DECIMAL: ±.005</p>		<p>MFG APPR: [ ]</p>							
<p>Q.A. [ ]</p>		<p>COMMENTS:</p>							



### B.4 TE-PM2.5C Drawing

ITEM NO.	PART NUMBER	DESCRIPTION	QTY.
1	TE-PM2.5C-1		1
2	TE-PM2.5C-3		1
3	TE-PM2.5C-5		1
4	TE-PM2.5C-4		1
5	TE-PM2.5C-2		1
6	92185A988 McMaster	10-32x3/8 SocketHd	2
7	026S70-ORING		2
8	008S70-ORING		2
9	025S70-ORING		2
10	015S70-ORING		4

DIMENSIONS ARE IN INCHES		NAME	DATE
TOLERANCES:	FRACTIONAL ±	DS	5-31-14
ANGULAR: MAJOR ±	TWO PLACE DECIMAL ±	CHECKED	
MINOR ±	THREE PLACE DECIMAL ±	ENG APPR	
		Q.A.	
COMMENTS:		TISCH	

PROPRIETARY AND CONFIDENTIAL  
 THE INFORMATION CONTAINED IN THIS DRAWING IS THE SOLE PROPERTY OF TISCH ENVIRONMENTAL. ANY REPRODUCTION IN PART OR AS A WHOLE WITHOUT THE WRITTEN PERMISSION OF TISCH ENVIRONMENTAL IS PROHIBITED.

REV	CHANGE	APPLICATION

FINISH	DO NOT SCALE DRAWING

SEE DWG. NO.	TE-PM2.5C
SCALE 1/2	WERK:
SHEET 1 OF 1	REV:

### B.5 TE-PM10 Drawings

#### TE-PM10 Lower Assembly Drawing



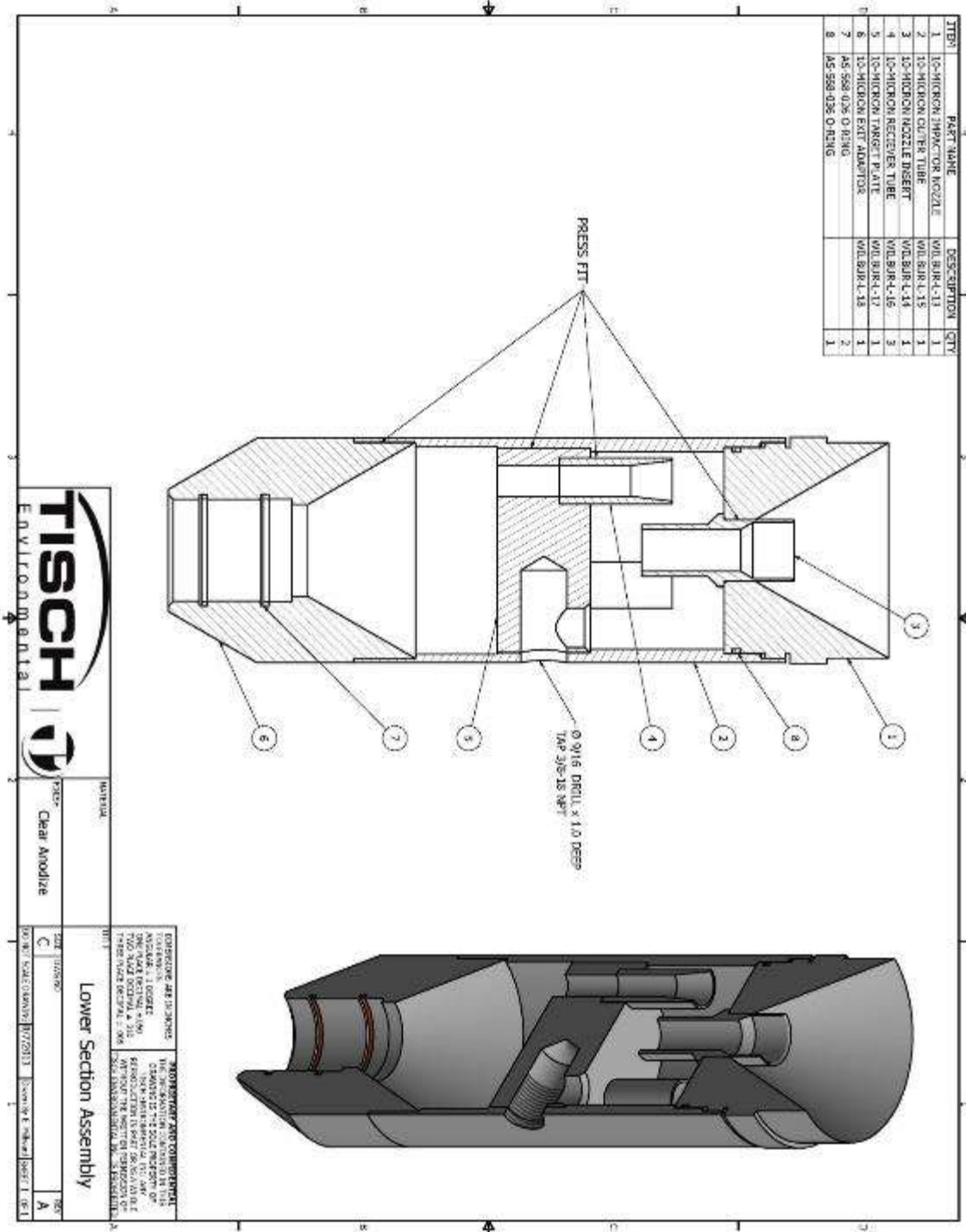

## Appendix C: Revision History

Revision No.	Date	Description
REV001	5-3-14	Manual created
REV002	5-5-14	Added quick start guide as Section 3.0
REV002.1	5-24-14	Added TE-Wilbur Calibration Worksheet and worksheet instructions to section 7.0 Calibration – created new section 7.9
REV002.2	6-2-14	Added TE-PM2.5C exploded view drawing
REV002.3	6-18-14	Updated MODBUS addressing, added updated pictures for connection plate and TE-PM2.5C, added TE-PM10 drawings and updated stand drawing, filter cassette drawing and pneumatic diagram
REV002.4	7-10-14	Updated several punctuation comments from USEPA designation and added several alerts
REV002.5	7-26-14	Added instructions 2.8 for changing language
REV002.6	8-23-14	Added USEPA Reference designation number
REV002.7	9-11-14	Added instructions and illustrations for unpacking of the unit Updated dimensions for PM2.5 and PM10 Updated fuse information
REV002.8	9-15-14	Updated USEPA Federal Reference Method designation and Federal Equivalency Method designation
REV002.9	10-3-14	Added louver filter maintenance section 13.20 Updated calibration worksheet with new version
REV002.10	11-1-14 11-4-14	Added warning about use of outdoor-rated cords Added USEPA FRM Designation numbers Updated screen for V1.80 of software. Changed last sample completed to sample summary screen
REV002.11	11-11-14	Added part number for TE-FRM-CAL calibrator
REV002.12	11-27-14	Updated electrical drawings in section 13.0 Added software revision history Appendix D

REV002.13	2-19-15	Updated manual to reflect flow setpoint changes of 90/95/100/105% of setpoint Updated solar panel configuration to include (2) panels
REV002.14	3-7-15	Added section 6.6 and documentation for new sample information screens that will give the user information for the last 5 samples completed
REV002.15	6-11-15	Added USEPA designations for using the TE-PM2.5C PM <sub>2.5</sub> fractionator

## Appendix D: Software Revision History

### Screen Revision History

Date	Version	Comments
9/28/14	1.10	Production version
10/9/14	1.70	Production version – changed version for USEPA FRM designation
10/29/14	1.80	Changed sample completed button and screens to sample summary
11/10/14	1.90	Changed ability for the screen to have its own software version
2/19/15	2.1	Changed the calibration system to be 90/95/100/105% of setpoint to ease calibration and allow setpoints to be closer to the system setpoint of 16.67Lpm. Skipped version 2.0 to allow screen to be the same revision level of the PLC
3/6/15	2.2	Added the ability for the user to view the last 5 sampling events onto the touchscreen

## PLC Revision History

Date	Version	Comments
9/28/14	1.10	Production version
10/9/14	1.70	Production version – changed version for USEPA FRM designation
10/29/14	1.80	Changed sample completed button and screens to sample summary
11/18/14	1.90	Multiplied CV by 100 to represent into percent. Changed maximum CV timer to 90 seconds from 60 seconds to allow sample flow to get up to speed more effectively  Changed sensor failure alarm timer from 30 seconds to 60 seconds to allow barometric pressure sensor time to boot up when plc firmware is updated
12/11/14	2.0	Changed battery discharge and battery fail alarms so they must stay maintained for 5 seconds before declaring a valid alarm
2/19/15	2.1	Changed the calibration system to be 90/95/100/105% of setpoint to ease calibration and allow setpoints to be closer to the system setpoint of 16.67Lpm.
3/6/15	2.2	Added the ability for the user to view the last 5 sampling events onto the touchscreen